

Cumbria Development Design Guide

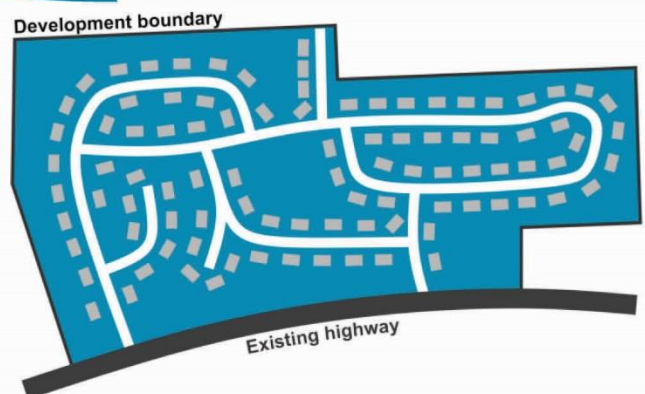

Part 1 New Residential Development

Part 2 Commercial Development

Table of Contents

Introduction	1
Purpose of this guide.....	1
Cumbria County Council's Approach – a Sense of Place.....	3
Place and movement.....	3
Managing the process	5
Provision of Pre-application Advice.....	6
Information required	6
Highway adoption process.....	7
Works within existing highway boundary	7
Boundaries of adopted highways	7
Health and safety (Construction Design and Management Regulations).....	8
Road safety audit.....	8
Consideration of risk	9
Adoption and use of open spaces	9
Part 1 New Residential Development	10
Chapter A. Road hierarchy	11
Permeability	11
Types of New Residential Highway	13
Footways & Cycle Tracks.....	15
Shared surface streets.....	15
Shared private access & Courtyards.....	16
One-way streets.....	16
Chapter B. Visibility	17
Important factors affecting visibility.....	18
Existing roads with actual 85 th percentile recorded speed data	20
Existing roads with unknown 85 th percentile speeds.....	21
Applying gradients	22
Cycleways & shared use facilities	23
Visibility at a junction.....	24
Visibility through a bend.....	24
Barriers to visibility at junctions	25
Visibility at private accesses	25
Junction spacing	26

Considering large vehicles	26
Chapter C. Carriageway widths.....	27
Future proofing	27
Typical vehicle widths	28
Typical carriageway widths	28
Roads	30
Access by emergency services	32
Carriageway width on a bend.....	33
Chapter D. Junctions & radii	34
Benefits of using minimum radii	36
Overrun areas.....	37
Chapter E. Turning areas.....	38
Turning area layouts	39
Refuse vehicle requirements.....	40
Chapter F. Speed management.....	41
Horizontal features.....	45
Vertical features	45
Psychological.....	46
Reducing visibility	46
Chapter G. Gradients	48
Dwell areas between roads.....	49
Carriageway widths with significant gradients	49
Choice of surface material	49
Surface water.....	50
Chapter H. Vertical clearance.....	51
Pedestrians and cyclists.....	51
Vehicles	51
Chapter I. Signs & markings	52
Signs.....	52
Markings	53
Chapter J. Parking	54
Importance of 'Good' design	56
Resident parking	56
Visitor parking	57
Parking bays	58
Courtyard parking	59

Traffic Regulation Orders and parking enforcement	59
Chapter K. Utility services.....	61
Maintenance issues	61
Planting.....	61
Depths and lateral positions	61
Chapter L. Lighting	63
Locating the lighting	63
Safety	64
Chapter M. Landscaping.....	65
Retention of existing landscape features.....	66
Carriageway proximity.....	66
Gateways.....	68
Adoptability of landscaping features by the Highway Authority.....	68
Species selection.....	68
Chapter N. Sustainable Drainage Systems (SuDS).....	69
Sustainable Drainage Systems (SuDS).....	70
The Management Train.....	71
Design Principles	71
Runoff Destinations.....	71
Flood Risk from the Proposed Development.....	71
Peak Flow Control.....	72
Volume Control	72
Pollution Control.....	72
Designing for Exceedance	72
Highway Drainage.....	73
Climate Change	73
Construction.....	73
Maintenance Requirements	74
SuDS Components	75
Part 2 Commercial Development	
Chapter A. Road hierarchy.....	77
Footways	77
Cycling.....	78
Shared Surfaces	79
Chapter B. Visibility	80

Chapter C. Carriageway widths.....	82
Additional width requirements	82
Over size loads	83
Chapter D. Junctions and Radii	84
Junction spacing	85
Junction control treatments	85
Radii	86
Chapter E. Turning areas.....	87
Vertical measures	88
Horizontal measures	88
Psychological measures	89
Chapter F. Gradients.....	90
Chapter G. Vertical clearance	90
Chapter H. Signs & markings.....	91
Development Boundary Signage.....	91
Development layout signage	92
Unofficial advertising.....	92
Markings	93
Bollards.....	93
Guardrailing	93
Chapter I. Sustainable Travel	94
Travel plans	94
Public Transport.....	94
Chapter J. Parking	95
Permitted on-street parking.....	96
Layout of privately owned car parks.....	96
Cycle parking	96
Chapter K. Utility services.....	97
Chapter L. Lighting	98
Chapter M. Landscaping.....	99
Chapter N. Access design.....	100
From the existing highway network	100
Chapter O. Mixed Use sites	101

Appendices

- Appendix 1 – Parking
- Appendix 2 – Development Management Fees
- Appendix 3 – Criteria for traffic assessment
- Appendix 4 – Highway Design Guidance – Residential
- Appendix 5 – Greenfield Site Calculations (to calculate APC bond)
- Appendix 6 – SuDS components
- Appendix 7 – Drainage Checklist
- Appendix 8 – Highway agreements / obligations
- Appendix 9 – Public Rights of Way Considerations
- Appendix 10 – Road Lighting Specification and Checklist

Document Control

Issue Date	Version	Revision Comments
Jan 2023	1.1	<ul style="list-style-type: none"> • Numerous minor changes to address consistency with Appendices • Various updates to reflect new legislation / guidance

Introduction

Over the next decade there are significant opportunities for Cumbria's residents, businesses and visitors to benefit from unprecedented levels of investment planned in key projects across the county.

Partners across Cumbria are working together to maximise these benefits and to enhance and promote the county as a great place for business innovation and enterprise with a world-class environment, landscape and quality of life offer.

Cumbria County Council is committed to playing a key role in delivering the best possible services for the people of Cumbria within its available resources. As Highways Authority and with its other responsibilities the Council - alongside the county's local planning authorities, developers, landowners, and other partners - plays a key role in the delivery of infrastructure and services to support communities.

As new housing and commercial sites are developed across the county, the aim of these guides are to ensure the design of new roads meet the needs of future residents, visitors and users whilst retaining the local distinctiveness of the area.

The highway network serving new residential and commercial developments in Cumbria should:

- Strive for excellence in design quality;
- Be beneficial to all; and,
- Improve quality of life for all those that have an interaction with the space

Good design adds economic, environmental, social and cultural value and helps communities flourish. This guide will help everyone involved in new developments to achieve good design and support an effective and efficient planning application process.

Purpose of this guide

This guide is for:

- Developers, landowners and property managers
- Architects, engineers, surveyors and designers
- Local Planning Authorities
- And all others involved in the design and construction of new residential and commercial developments in Cumbria

The purpose of this guide is to provide advice and guidance on the design elements that combine to create successful residential and commercial developments in Cumbria.

This guide is not intended to give definitive legal advice and is for guidance purposes only.

This success will be measured in a variety of different ways including factors such as:

- Safe movement for all within the development
- Improvement in quality of life
- Maintainable built environments
- Integration with and enhancement of the existing community
- Low traffic speeds

This guide supersedes the Cumbria Design Guide, Volume 1 – Layout of Residential Developments, 1996. This new guide is less prescriptive and places more emphasis on the development of innovative proposals

The guidance set out in this document takes account of current national policy, best practice national guidance, and the requirements of the Cumbria Lead Local Flood Authority formed under the Flood and Water Management Act 2010 with regard to Sustainable Drainage Systems or SuDs.

The guide gives a clear indication how the lead Local Flood Authority and Local Highway Authority will respond to planning applications for new developments.

Context and good practice

Planning law prescribes circumstances where consultation must take place between a local planning authority and certain organisations, prior to a decision being made on an application. The organisations in question are under a duty to respond to the local planning authority within a set deadline and must provide a substantive response to the application in question.

Cumbria County Council is a statutory consultee to the Local Planning Authorities as the Highways Authority as outlined in the Planning and Compulsory Purchase Act 2004, Localism Act 2011, The Town and Country Planning (Development Management Procedure) (England) Order 2015 (Schedule 4 items k, l, m, n), Freedom of Information Act 2000 (Part I, S16) and the Highways Act 1980

Cumbria County Council is also the Lead Local Flood Authority (LLFA) as defined by the Flood and Water Management Act 2010 (FWMA) and as such we have a duty to manage flood risk throughout Cumbria; this includes the risk of flooding from new development and redevelopment.

This guide is intended to be used by designers, developers and planners to ensure a consistent approach to Sustainable Drainage Systems throughout Cumbria as well as helping us to fulfil our duties under the FWMA whilst supporting growth in a sustainable way.

It is not intended that the guide will be a Supplementary Planning Document (SPD) in its own right but that the guide will have weight in the planning process by outlining how the County Council will respond as a statutory consultee. It should however be noted that the County Council through the consultation process on Local Plans will be encouraging the Local Planning Authorities to include elements of the guide within their Local Plan documents.

Since 2010 the government has substantially reformed planning policy, with the introduction of a streamlined National Planning Policy Framework (NPPF).

The NPPF emphasises that design quality matters and that planning should drive up standards of development. The government has placed an expectation on all planners and decision-makers to always seek to secure high quality design.

This guidance has been substantially informed by the principles and practice set out in the government's 'Manual for Streets' and the Chartered Institute of Highway and Transport's (CIHT) 'Manual for Streets 2'. These Manuals place people at the core of the design process – as the users of residential areas as residents, employees, drivers, cyclists, and walkers – with pedestrians considered first.

The principles and practice promoted are:

User hierarchy
Team working
Community function
Inclusive design
Pedestrian / Cycle support
Master plans / Design codes
Connectivity / Permeability
Frontage access
Stopping sight distance
Minimise signs and street furniture
Quality audits

The two Manuals are accessible at:

[Manual for streets - Publications - GOV.UK](#)

[Manual for streets 2 - Publications - GOV.UK](#)

Cumbria County Council's Approach – a Sense of Place

This guidance builds on the practice set out in the Manuals and the *Re-creating the street* approach for designing highway within a new residential development, whilst recognising that in different situations there could be a number of factors that would mean that other solutions are appropriate.

The successful adoption of the principles and practice set out in the Manual for Streets and this guidance requires a collaborative approach to the design between the developer and the highway authority. It is important to ensure that sufficient information is provided to help to inform the design process. Communication between these bodies is essential if the best design solutions are to emerge.

Place and movement

The choice of the word 'street' has been carefully selected as it highlights the distinction between what is a street and what is a road. A street is concerned mainly with its immediate surroundings including buildings and public spaces whereas a road is focussed more on the facilitation of vehicular traffic movements.

We all know our place when it comes to interacting with the highway - pedestrians keep to the very edges whereas faster travel modes will occupy the space nearer to the centreline of a carriageway.

This is how things have developed and has become the standard model for how a highway operates and it is generally understood by all road users. Increasingly in recent times however there has been the recognition that this model can no longer be considered acceptable in places where pedestrian flows are high and if not high, then at least comparable with the flow of motorised traffic.

Residential developments are considered to be such places and it is this recognition of the term 'place' which has led to a re-

establishment of road user needs in those areas. As the importance of place increases then there is a consequence of lower priority being afforded to movement. The creation of a sense of place in new residential developments is a vital element of a successful scheme design.

The Manual for Streets diagram below – Figure In1 - demonstrates that although movement is given a lower priority than place in residential developments this does not mean that there is any barrier working against it. The main restriction on movement is in relation to motor vehicles and the designing out of layouts which will allow traffic speeds that are a concern for other road users.

These lower speeds allow better integration of all road users without the need for segregation seen on roads with higher design speeds. Dominance by motor vehicles is no longer an acceptable situation in these areas and it is now an ambition that developers can deliver schemes which create environments where all road users are afforded mutual consideration.

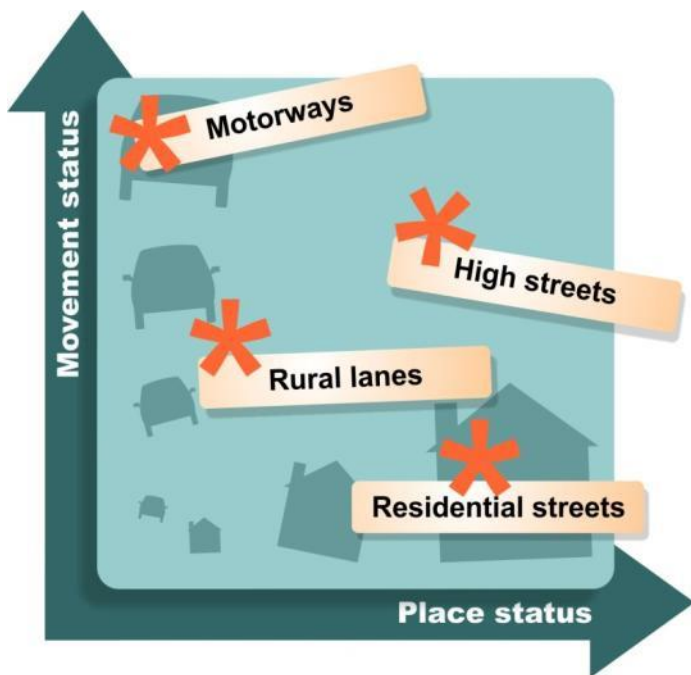

Figure In1: Movement / Place status matrix

Motorways

All about moving at high speed, with infrequent delays and low chance of conflict between vehicles.

High streets

A destination for many with all types of road user mixing in substantial numbers. Not generally identified as a through route.

Rural lanes

Important for allowing people to move between destinations but also have some place status due to the scenery and low traffic levels.

Residential streets

Tend to be the end destination or origin of trips for people so traffic is low and slow putting greater emphasis on the place itself.

A hierarchy of road users in new residential developments will generally prioritise those who are most vulnerable or those seeking access to public transport above all other modes of transport. This 'scale' of prioritisation in the design process can be demonstrated in Figure In2 below.

Permeability and ease of access for pedestrians is essential to the successful design of residential developments. The correct identification of desire lines and removal of barriers all help to encourage an environment which is dominated by the non-motor vehicle road user. Additionally, the encouragement of walking and cycling is beneficial to peoples' health through exercise and the reduction in pollution associated with motor vehicles.

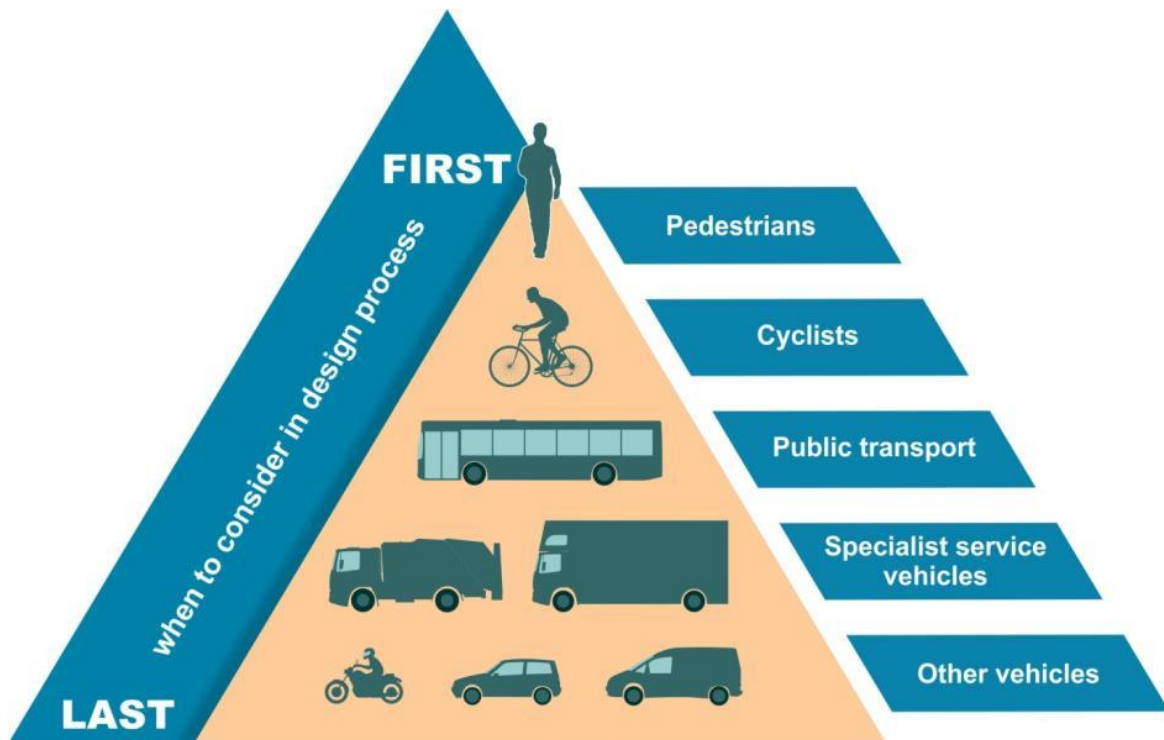

Figure In2: *Prioritisation of road users when designing new highway*

Managing the process

Cumbria County Council seeks to ensure that developers are able to provide a design which is satisfactory and can be adopted as part of the highway network. Where issues or potential conflict arise in respect of design features and quality, engagement at an early stage with the Council – through the Development Management Team – is highly recommended.

There are situations however where conflict can arise between the minimum standards required for new developments and the advice given through Manual for Streets (MfS). Although the introduction of MfS has allowed a relaxation in some design standards there is a need to ensure that permitted designs continue to deliver the best possible options for the future of the development.

It is equally vital that this aim is not compromised, which may occur if there is a failure to deliver the appropriate solutions simply because MfS indicates that rules could be relaxed.

The best solution to this conflict is good communication between the concerned parties.

Deviations from the standard details that are provided within this guide are possible, but these must be discussed and agreed with Development Management Officers from Cumbria County Council. The Highways Authority will seek to work with both the Local Planning Authority and Developer to ensure where possible that the highway network is adopted.

Contact details:

Flood and Development Management Team, Parkhouse Building, Carlisle, CA6 4SJ - 01228 221331

DMandLLFA_west@cumbria.gov.uk – Allerdale & Copeland

DMandLLFA_south@cumbria.gov.uk – South Lakeland & Barrow

DMandLLFA_east@cumbria.gov.uk – Carlisle & Eden

Early engagement with the County Council in any design process will enable potential issues to be identified early and mutually agreeable solutions to be formed, saving time, effort and costs

Provision of Pre-application

Advice

The County Council welcomes and encourages discussions before a developer submits a planning application.

These discussions can result in better quality applications which stand a better chance of a successful outcome and help speed up the decision-making process after submission. As a consequence, they can help to minimise subsequent costs and avoid abortive applications. Consultations should include discussions on sustainable drainage as a key requirement on NPPF.

There will be a charge for pre-application discussions, further information on this can be found in Appendix 2

Information required

In order to be able to provide useful advice and guidance, a sufficient level of information needs to be provided before any pre-application advice is given.

For **Small** developments (single dwelling / householder applications) , the minimum information required is as follows:-

- Site address
- Site plans (showing location, boundary, existing and proposed site layouts including access arrangements)
- Description of proposed development.
- Drainage proposals for foul and surface water.

For **Minor (5 dwellings or fewer) or Major or Strategic** proposals in addition to the above, the scope of information to be provided should be discussed with the Local Highway Authority but could include the following information:-

- Details of the existing use of the site, including planning permission history if applicable.
- A Stage 1 Road Safety Audit (including copy of the brief and designer's response) for the

proposed site layout and/or access arrangement together with amended plans.

- Relevant data collected to date, such as traffic counts, accident history, speed surveys.
- Summary of reasons supporting site access/highway works proposals, including plan (scale 1:200) with achievable visibility splays indicated.
- Scoping for a Transport Statement / Assessment or a draft of these documents.
- Location plan of key services and facilities indicating locations of education, employment, food and non-food retail, health care and public transport facilities.
- Parking Strategy, including provision of parking for all forms of transport.
- Any further information considered critical to the proposal at pre-application stage.
- Flood Risk Assessment/Statement
- Drainage Strategy/ Statement & Sketch layout plan
- Details of any existing rights of way which may need to be stopped/up or diverted. Appendix 9 provides further guidance on this matter.
- Further detail on standards that the County Council expect developments to comply with can be found in Appendix 4.

Where the Highway Authority is invited to attend a pre-application meeting, all of the relevant information should be provided 10 working days prior otherwise the meeting will need to be rescheduled.

Upon receipt of all necessary information, the Council will aim to provide a written response (either by email or letter) within 21 days.

Please Note

The Highway Authority and Lead Local Flood Authority formal response to any planning application is made taking account of revisions to the proposals, any changed circumstances and/or information. As such, we cannot offer pre-application advice that can bind the Council but we will give you the best advice possible based on the information that you provide. The final decision on any planning application is taken

Highway adoption process

Further detail in relation to the highway agreements and processes can be found in Appendix 8. Developers/designers should also refer to Appendix 4 Highway Design Guidance – Residential when designing any proposed Section 38 layout

With the exception of private shared driveways, housing estate streets must be designed and constructed to a standard considered acceptable for roads likely to be adopted as highways maintainable at public expense.

A new road can be adopted by Cumbria County Council into the highway network if;

It serves more than five dwellings; and

It has been constructed to a standard acceptable to the county council highways department; and

It uses a design speed of 20mph as its upper limit; and

It provides sufficient parking places for residents and visitors; and

It serves a highway purpose

Does not lead to potential ransom demands in the future

By encouraging a more innovative approach from developers to designs, it is conceded that the adherence to a strict list of design standards is unlikely to assist in this aim. This creates a potential weakness in this new approach as if standards are no longer absolute requirements, developers may produce designs which are not considered to be acceptable by the Highway Authority.

Manual for Streets does suggest a number of ways in which this weak or 'grey' area could be lessened such as the provision of compelling evidence by the developer to prove that a design will satisfy.

Every one of these suggestions will work best if both the developer and the Highway Authority

are able to communicate early on in the design process.

Works within existing highway boundary

Developers are reminded that no works can take place in the existing highway without the approval of the Highway Authority. Any works within the highway shall only take place when appropriate licences have been issued and /or a Section 278 Agreement has been signed.

Further detail in relation to highway agreements / obligations can be found in Appendix 8. Developers/designers should also refer to Appendix 4 Highway Design Guidance – Residential when designing any proposed Section 38 layout

Boundaries of adopted highways

Highway boundaries in residential developments should be clearly indicated physically on the ground in some manner. The method by which this is done should not detract from the character of a street or road.

An adopted highway verge which is adjacent to private gardens on an open plan estate will require special attention to ensure that the rights of the Highway Authority, statutory undertakers and the public are fully understood by purchasers of the adjoining property.

Developers should ensure that grassed areas which are required to form part of the adopted highway are not conveyed to future purchasers in advance of a Section 38 road adoption Agreement being entered into, so that the Developer has the legal capacity to dedicate all necessary land as highway.

Purchasers must be made aware that if the grassed areas/highway verges are conveyed to them following the entering into of the Section 38 Agreement that they will be required to ensure that the new owners should be prohibited from building walls or fences or planting trees or shrubs on the grassed areas/highway verge so as to restrict visibility and that the statutory undertakers may excavate their services at any time.

The Highway Authority will work with the Local Planning Authorities to ensure that no ransom strips are left at the end of turning heads. Adoption should therefore extend to the edge of the land ownership/title boundary and Section 38 Agreement drawings should clearly reflect this, with suitable dimensions.

Prior to the entering into of a Section 38 Agreement, an Advance Payment Code Notice (APC) may be served following the passing of plans by the relevant Planning Authority. This Notice requires the payment of a sum to the Council in satisfaction of the cost of making up the private street to an adoptable standard before building works commence. Such a Notice is generally only discharged, and any payments made refunded, once the Section 38 Agreement is entered into or the private street is adopted as highway maintainable at the public expense. Please see Appendix 8 for further details of the APC procedure. Geotechnical features shall be designed and certified in accordance with *BS EN 1997-1 Geotechnical Design* and the Design Manual for Roads and Bridges *HD 22/08 Managing Geotechnical Risk*.

Geotechnical features to which these procedures apply includes earthworks, strengthened earthworks and earth retaining structures supporting the highway or otherwise near it, whether or not they are to be adopted as publicly maintainable. HD 22/08 defines the features more fully and describes the technical requirements, standards and formal certification procedures that should be met.

Further details can be found in Appendix 5 in relation to commuted sums.

Health and safety (Construction Design and Management Regulations)

No highway adoption shall be made without a suitable Health and Safety file being submitted which shall include all record drawings of roads, drainage and road lighting.

Road safety audit

The following extracts are taken from Cumbria County Council's policy on road safety audits and

'All schemes, regardless of cost, that have a significant impact on road users or make significant changes to the highway geometry, traffic flow, lighting, signalling, signage, landscaping or carriageway markings will be subject to a full Road Safety Audit'.

'All new road schemes and highway improvements which have a more minor impact on road users will be subject at a minimum to a safety check in the form of a brief Road Safety Advice Note.'

demonstrate their direct relation to new developments and changes to the existing highway.

The road safety audit process is used to identify any issues with a new highway design or change to existing highway that could pose a risk to a road user. Road safety audits are carried out independent of any persons involved in the design. The aim is to provide a fresh and uninfluenced opinion on a scheme. Upon identifying any issues, a report is prepared which makes recommendations intended to mitigate against them. These recommendations could suggest the removal of certain elements from the design or possibly a replacement design feature that would better guarantee road safety.

Road safety audits are a requirement of both the Section 38 and 278 agreements as they are essential components of the highway adoption process.

Everyone must play their part in ensuring safe environments are being developed and while the audit report must be done in isolation by the audit team, group discussions with road safety experts are encouraged

A Stage 1 Road Safety Audit together with the brief and copies of the information provided should be submitted as part of the planning application for the development. This helps to avoid significant issues arising at later stages once planning consent has been granted and also provides evidence with regards the safety of the design in order to satisfy both Highways and Planning Authorities.

A Developer may request Cumbria County Council to undertake a road safety audit on their behalf or they may appoint an external party for the purpose. There is a cost associated with either option to cover the vetting process.

Consideration of risk

Developers may be aware from the outset of a scheme of potential risks in their design which would be picked up by a road safety audit. If these risks have been considered fully and if the likelihood and resultant severity of any incident is determined to be low then the design could remain as planned without the need to make changes.

The Chartered Institution of Highways and Transportation (CIHT) made provision for introducing likelihood of collisions and resulting severity of those collisions in their paper *Highway Risk & Liability Claims, A Practical Guide to Appendix C (UK Roads Board, 2005)*. Currently, Cumbria County Council require this risk assessment be used for any issue raised through a road safety audit report in conservation areas and town centres within the County.

It is therefore necessary that all applications requiring works within the highway to be accompanied by a stage 1/2 safety audit, to ensure that all safety aspects of the works are identified and remediated.

Adoption and use of open spaces

The Highway Authority will adopt grassed areas/verges as publicly maintainable only where there are adjacent Local Distributor Roads and improvements.

on lower category streets only where required for highway visibility, vehicle overhang, statutory services or to enable future highway. Such maintenance will exclude trees, shrubs and ground cover planting, none of which will be accepted within highway unless the developer has made secure arrangements for their future maintenance. This will normally occur through a financial contribution though a Section 106 agreement.

In respect of other open space within housing sites, developers will need to ensure that secure arrangements are made for future maintenance and these arrangements should be made explicit at the planning application stage. This may appropriately be undertaken by individual residents if the space is to be allocated to individual ownerships during the sale of property. In other instances, the developers will themselves need to make arrangements for the ongoing maintenance which will need to be recognised in a legal agreement. As above, these spaces should clearly be defined in a Section 106 agreement.

Open spaces can help with SuDs design by maximising the benefits for water quality, water quantity, amenity and biodiversity.

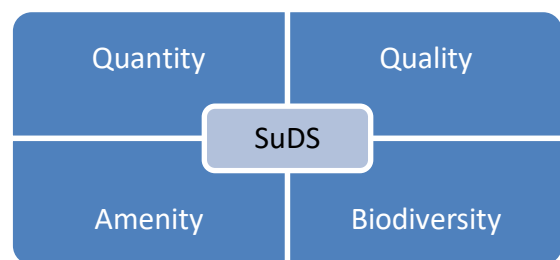

Part 1: New Residential Development

Chapters

- A. Road hierarchy**
- B. Visibility**
- C. Carriageway widths**
- D. Junctions and radii**
- E. Turning areas**
- F. Speed management**
- G. Gradients**
- H. Vertical clearance**
- I. Signs and markings**
- J. Parking**
- K. Utility services**
- L. Lighting**
- M. Landscaping**
- N. Sustainable Drainage Systems**

Chapter A. Road hierarchy

This guide provides recommendations as to the most suitable geometry and best practice advice to use in designing new sections of adoptable highway. Amongst the most problematic issues when it comes to applying MfS is that the advice can be found to be **too flexible**. The risk associated with this flexibility is that designs could be produced which fail to perform well once constructed leading to the introduction of remedial works that can ruin an area's character. Minimum standards for certain elements within a development are therefore necessary to ensure that new additions to the highway network are acceptable for adoption.

It is for this reason, that a general description of the road types expected to form or connect to residential developments has been included here along with some baseline standards expected to apply to each type. Developers are reminded that early consultation between themselves and the Highway Authority will allow for early decisions to be made on any departures from these recommendations. There is no reason why any particular issue cannot be discussed and negotiated if compelling evidence can be provided for departing from the recommendations given here.

The classification and treatment of a road appropriate to its function is essential in maintaining a reasonable balance between the safe and efficient accommodation of all road users without causing unnecessary delay or unreasonable hardship on any one particular group.

In general, it should be the case that any new road which has a principle purpose of serving residential properties will be suited to traffic types and flows appropriate to that purpose.

By designing to this function, as opposed to a demand, the concept of 'place' can play a significant role in the creation and sustaining of an area's character, community and other facets which have a value and benefit to quality of living.

Residential developments, with their emphasis on people, means that the streets which serve them will be expected to have low traffic flows and low numbers of heavy vehicles using them.

Permeability

The ability of people to move through a development and to connect efficiently with the existing road network is vital and should be a primary consideration in new layout designs. This desire for permeability is one that is shared by all road users, from those on foot to those operating private motor vehicles.

Generally, it will be the case that the larger a development is then the greater the need will be for multiple connections with the network. The purpose behind this is to minimise any disruption to a majority, if not all residents if sections of road are subjected to a closure or blockage of some kind. In addition to this a permeable layout allows for a diversity of movement options which helps to create dynamic streetscapes, rather than a car dominated layout.

Severance of routes should be guarded against through the provision of appropriate alternatives. Designs must also anticipate any misuse of this new network by non-residents simply who seek to use the road as a short-cut. This should be discouraged through the selection of alignments and features which will manage traffic speeds.

Figures RH1 to RH5 collectively draw a comparison between a non-permeable development and one that has been designed with permeability in mind.

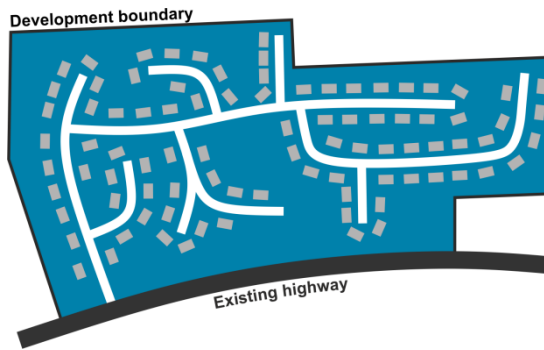

Figure RH1

This layout shows a development that is served by a single access and the streets which end in a cul-de-sac arrangement. The following diagrams demonstrate the options which a developer should explore through their designs to achieve permeable movement.

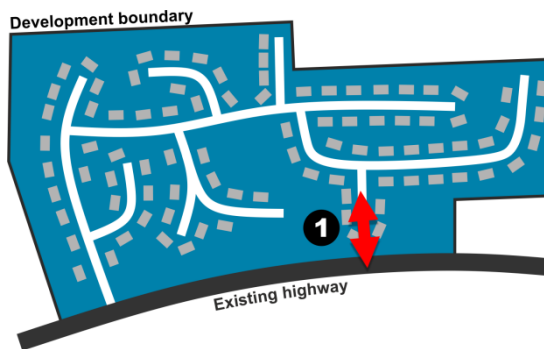

Figure RH2

The introduction of a second access (position 1) onto the existing highway network effectively splits the traffic flow between the two. This reduces the impact of the traffic on residents living near the entrance and reducing the distance that residents at the far end of the development need to travel before exiting the site.

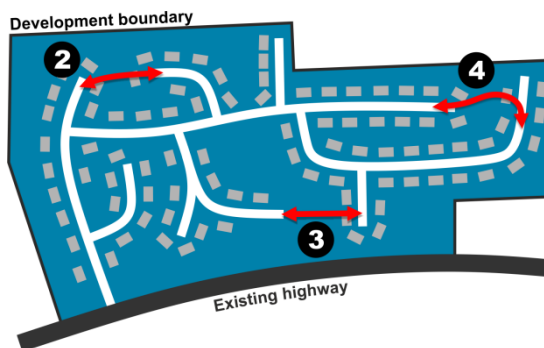

Figure RH3

Positions 2, 3 and 4 in the above diagram highlight areas within the layout where links could be incorporated. This adaption to the layout creates a situation where reversing

manoeuvres are kept to a minimum which is advantageous in an environment where vulnerable road users are to be expected.

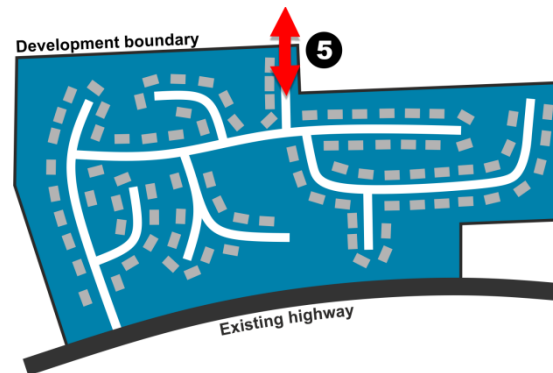

Figure RH4

Future development may already be identified through land allocation plans as likely to occur beyond the current boundary of the site. If further expansion to the site is likely an appropriate termination treatment should be used on the most suitable link into the future development. Position 5 approaches the development boundary edge.

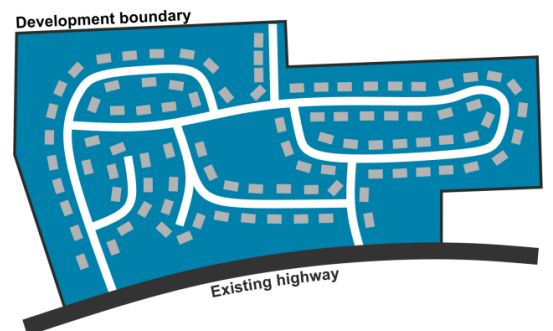

Figure RH5

This final diagram is a composite of all five amendments that could be applied to the original layout design. The result is a layout that delivers better conditions for all road users by removing barriers to their movement. It should be easier to navigate, safer for those not in a vehicle and more favourable to situations where emergency vehicles require access or road closures are needed.

It is accepted that permeability will not always be an achievable option for some developments due to topography, existing network alignments or other reasons that are in some way prohibitive. Developers should always demonstrate that they have at least considered this approach in the design process.

Types of New Residential Highway

The following table sets out the typical types of road which are be expected to make up a residential development and includes a brief description of the recommended attributes that each road should have in order to satisfy its functionality.

Primary Road



- More than 100 dwellings. A secondary vehicular access is required for more than 100 dwellings.
- 20mph (maximum) target speed
- Footway width: 2000mm (both sides of carriageway)
- Carriageway width: Assume 5500mm (6000mm if bus route, widening to 6750mm if on-street parking is to take place)
- Largest vehicle: HGV
- Direct access to dwellings served by existing streets are permissible if speeds are within a 30mph limit
- Limited on-street residential and visitor parking to be designed into the layout

Secondary Road



- Up to and including 100 dwellings
- Emergency Vehicle access required for more than 50 dwellings and secondary vehicular access is required for more than 100 dwellings.
- 20mph (maximum) target speed
- Footway width: 2000mm
- Carriageway width: 5.5m (4.8m minimum if than 50 dwellings)
- Largest vehicle: Panttechnicon
- Direct access to dwellings permissible if speeds are within a 30mph limit
- Limited on-street residential and visitor parking to be designed into the layout

NB

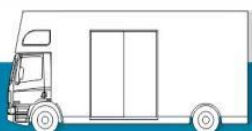

Panttechnicon is a term which refers to a 'removals' vehicle

Shared Surface Street



- Up to 25 dwellings (cul-de-sac) or 50 dwellings (loop) on section which should not be more than 70m
- 15mph (maximum) target speed
- Footway width: Not applicable
- Carriageway width: 4800mm
- (4100mm min at non-access frontages and for a distance of no greater than 24m)
- Largest vehicle: Pantechicon
- Includes alternative features and means for visually impaired people to navigate by

Lane



- Up to 25 dwellings
- 10mph (maximum) target speed
- Footway width: maximum of 1 with minimum width of 1200mm
- Carriageway width: 3700mm (first 15m of carriageway from junction to be 4800mm wide) - provide passing places every 40m
- Largest vehicle: Pantechicon

Shared private access & Courtyard



- Up to 5 dwellings
- These are not adoptable streets as they do not form part of the public domain however where they meet the adoptable network designs must address required visibility splays and surface treatments
- These streets would not be adopted, provided they were not capable of being extended in future years
- 10mph target speed
- Single track 2750mm (3700mm minimum if access is required by fire appliance)
- These are also treated as being exempted from the APC.

Footways & Cycle Tracks

Other types of highway which may be adoptable by the Highway Authority include footways and cycle tracks that do not follow the route of the main carriageway.

Footways

Footways are fully adoptable as highways just as long as they form some useful part of the network. They must be provided where shared surface solutions are not possible or are determined not to be appropriate. 2m is usually sufficient width to accommodate foot traffic as ample space is available for pushchairs, wheelchairs and mobility scooters. Routes which include steps will not be considered for adoption.

Cycle Tracks

It is an important requirement that any new highway should be able to incorporate cycles and permit them to travel with low risk. This is to be achieved through the application of low design speeds and a conscientious design layout. There are instances however when cyclists should be allowed, even encouraged to leave the confines of the carriageway and take advantage of the flexibility which cycling promotes.

The advantage of implementing an off-road cycle route is that it can create a permeable and more direct route within the residential development compared with the main carriageway. This should be an advantage to the cyclist through reductions in journey times and a further reduction in the risk of collisions. There may also be the opportunity for these off-road routes to link in with other cycle facilities outside of the development creating a comprehensive and convenient network.

Any facility that takes people away from the main carriageway will have to consider the safety of its users in terms of their personal security. Designs will need to demonstrate attention has been paid to mitigate against anti-social abuse of the facilities by motorised and other inappropriate vehicles.

Care must be taken where site outlines contain or border Public Rights of Way, please contact our Countryside Access team.

Shared surface streets

Shared surface environments are a prime example of place over movement with the absence of physical footways encouraging all road users to be better behaved to one another as no single individual has been given priority over another. Respect is an important contributor to the success of these types of development and it is the responsibility of both pedestrians and drivers to allow for each other's presence within the space.

These streets tend to work best where pedestrian footfall is already high or is intended to be so through the creation of the new development. There is also the need for traffic speeds to be low or guaranteed to be lowered through other measures prior to the shared surface area being entered. These shared surface streets should only be used where there is justified case for their inclusion. They should not be chosen as a design solution if there is little chance of any practical success.



Figure RH6: *Shared footway and cycle track through a residential development overlooked by properties*

Where multiple desire lines (the most direct and desirable routes) are present for pedestrians, the shared surface can offer a good alternative option to the traditional formal application of straight footways with crossings. Such formality can create frustration for pedestrians who will often choose their own routes rendering the design inefficient.

The choice of surfacing material to apply to the shared surface will determine how well it is understood by road users. Visual clues should be included in the design that will create safe areas for pedestrians. These areas should act as portions of the highway where vehicles are less likely to enter even on a shared surface and could be created through a visual segregation line created in the surface through some appropriate method.

The use of shared surface areas will only ever be acceptable if the concerns of impaired users are addressed. Developments should also strive to be “Dementia Friendly”. The common problem that shared spaces can present for visual impairment includes confusion due to the blank canvas of highway without easily identifiable infrastructure to follow. Appropriate mitigation measures must be built into the design to allow access for all.

Shared private access & Courtyards

Although these private access arrangements will not be adopted by the local highway authority, the transition point where they join the adopted highway network must be clearly marked and constructed to a standard that is acceptable to the Local Highway Authority.



Figure RH7: *Shared private courtyard*

Gravel and other loose chippings are often used on private drives which are not adopted by the Highway Authority. It is important that design measures are in place to negate the possibility of this surface being transferred onto the adopted highway. In order to achieve this, gravel traps can be used to provide the necessary barrier. The gravel trap must be constructed from a bound material that does not shift and could be created to replicate the appearance of the loose gravel section of the unadopted road. The first 5m of the private surface should be bound to provide an adequate distance over which loose materials can be cast off.

The preference is that this transition point should also use a design feature which makes it visually obvious where the adopted highway ends and the unadopted surface commences.

One-way streets

Generally the presumption is that one-way carriageways are not to be recommended for new developments. The main reason behind this recommendation is the concern over traffic speed and road safety. This issue can emerge due to drivers being able to navigate the street unopposed by oncoming traffic and therefore confident that they can proceed at speed with minimal caution. Any environment where place plays a significant function will likely suffer as a result of this.

One-way systems will necessitate the introduction and enforcement of a Traffic Regulation Order and the additional infrastructure that is consequently required. Any design which will lead to the requirement of signs and lines in order for them to be effective will not generally be viewed as appropriate to a residential development and should be avoided.

Chapter B. Visibility

The ability to have a good view of the road ahead either whilst continuing along a road or when emerging from a junction is essential to the safety of all road users.

Instances where visibility of the highway will be of particular importance will be at:

- junctions
- bends, and
- vertical crests

Being too generous with visibility provision can be detrimental to safety however as it can facilitate higher traffic speeds. A balance needs to be struck in terms of designs that can adequately cater for safe travel and manoeuvres but also encourage low speeds in residential areas.



Figure V1: Bend with limited forward visibility

Visibility plays can be split into two main categories:

Stopping Sight Distance

This is the forward visibility that a driver has of the carriageway ahead of them and the minimum distance at which an obstacle must be visible to the driver so adequate time and distance is available for safe braking. The distance is a combination of reaction distance (of the driver) and braking distance (of the vehicle).

Visibility Splays at Junctions

This is the scope of vision that must be available to a driver at a junction when they are entering a major road from a minor road. There is a minimum distance that the driver's vision must be unobstructed for along the major road and this is dependent on the traffic speeds on that major road.

Important factors affecting visibility

- Visibility should be checked at accesses, junctions, and along the road.
- Visibility is measured both horizontally and vertically.
- Using plan views of proposed layouts, checks for visibility in the horizontal plane ensure that views are not obscured by vertical obstructions.
- Checking visibility in the vertical plane is then carried out to ensure that views in the horizontal plane are not compromised by obstructions such as the crest of a hill, or a bridge at a dip in the road ahead.
- It also takes into account the variation in driver eye height and the height range of obstructions. Eye height is assumed to range from 1.05m (for car drivers) to 2m (for lorry drivers).
- Drivers need to be able to see obstructions 2m high down to a point 600mm above the carriageway for forward visibility requirement or the Stopping Sight Distance (SSD) for link design. The latter dimension is used to ensure small children can be seen by the driver of a vehicle travelling along the road.
- For visibility at new junctions (or accesses) the splay ensures there is adequate inter-visibility between vehicles on the major and minor arms. Therefore, the lower vertical envelope is taken at eye-height (1.05m) for both the drivers on the main road and side road. This is because vehicles having turned into a side road or access are travelling far slower than the main road free flow speed.
- The above consideration for side roads and accesses accommodates boundary features and planting within the splay up to a height of 1.05m to be accommodated.

The red area in Figure V2 shows the minimum field of view which must be unobstructed in order to satisfy the SSD requirements. An object of 600mm in height must be visible from a driver's eye-line ranging between 1050mm and 2000mm. The area shown in the blue circle showing a length of 2400mm is the 'average' distance between the front of a vehicle and the driver's head position within the vehicle.

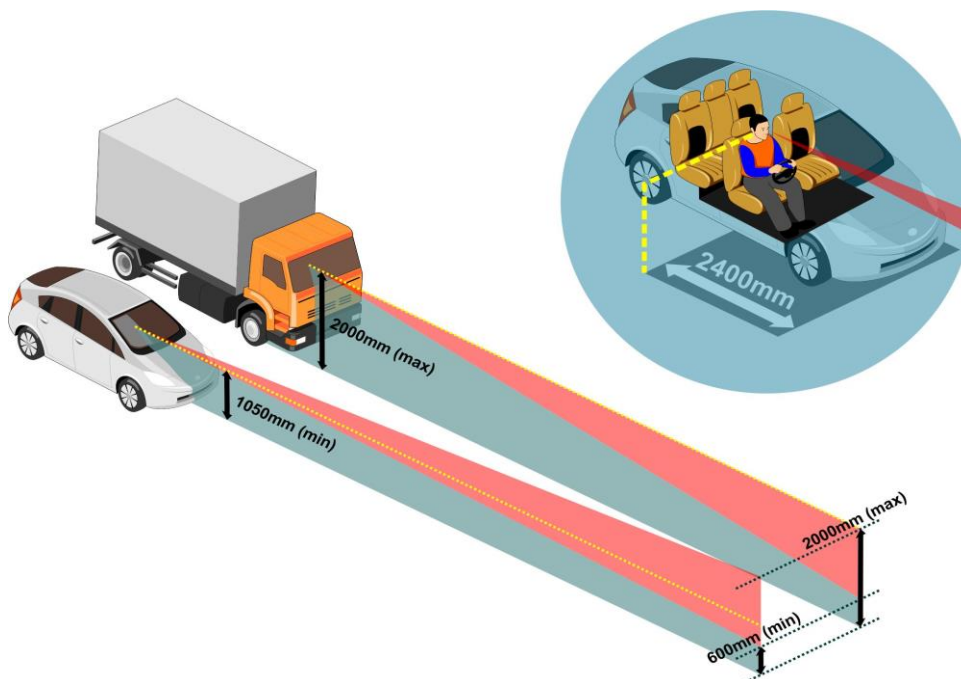

Figure V2: range of vertical visibility required by vehicles

$$\text{SSD} = \overset{\substack{\text{speed (m/s)} \\ \text{driver perception - reaction time (s)}}}{vt} + \frac{\overset{\text{deceleration rate (m/s}^2\text{)}}{v^2}}{\underset{\substack{\text{longitudinal gradient (\%)} \\ \text{2 (d + 0.1a)}}}{2 (d + 0.1a)}}$$

The calculation above, used to derive the Stopping Sight Distance (SSD) is comprised of two component calculations, one for each type of distance being measured. The first part of the calculation finds the 'reaction distance' whilst the remaining part which is then added finds the 'braking distance'.

using the data from DMRB, that it was created by the Highways Agency, specifically to design for trunk roads and it is therefore not suitable for applying to residential streets without any critical analysis being done.

An SSD uses a wet surface as the basis for determining the total distance required and is done so to ensure that a worst-case scenario has been considered.

Figure V3 shows which units should be used in the SSD formula if a manual assessment is undertaken to find a total. The Figure shows that where design speeds are below or equal to the 37mph threshold, the driver perception reaction time is less than for speeds in excess of this. The rate of deceleration is more rapid when starting speeds are low

MfS uses an indicative ceiling of 37mph, below which its principles and guidance can be used with confidence. Above this threshold figure of 37mph it is therefore considered more appropriate to switch back to the DMRB figures which were used previously in all situations. It is important to appreciate when

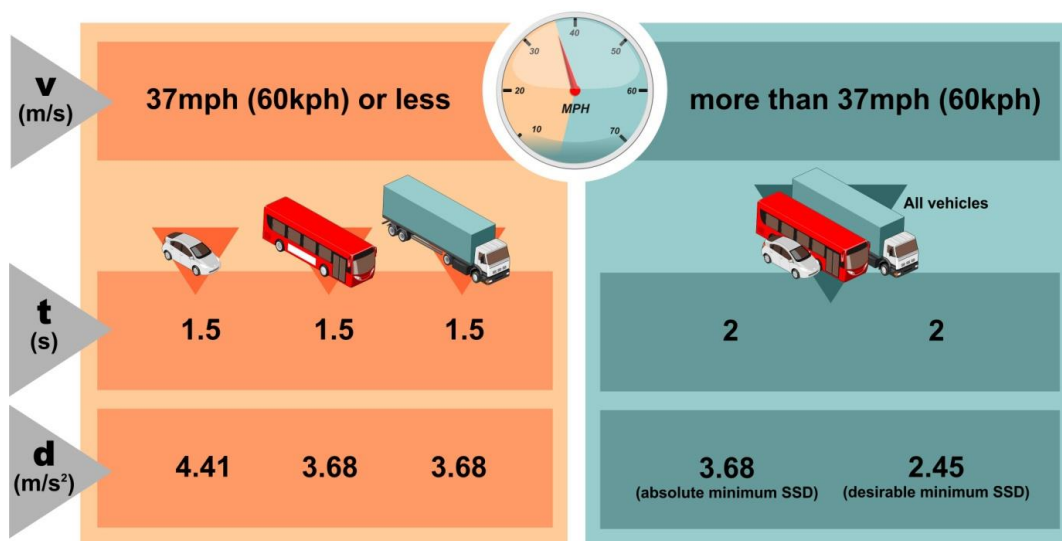

Figure V3: values and units to be used in SSD calculation

Existing roads with actual 85th percentile recorded speed data

It is always preferable to use the actual 85th percentile recorded figures of traffic speeds on existing roads. This is due to that data providing the best method for generating an accurate design. Figure V5 shown below shows a detailed selection of SSDs from MfS which are suitable for existing roads that have had their 85thile speed surveyed and found to be up to and including 37mph.

An additional length of 2.4m has been added to the SSD values to give the values shown within Figure V5. These values are appropriate for light vehicles such as cars and vans which would be expected to constitute the vast majority of traffic on a residential development highway.

The SSD values given in Figure V5 have been generated based on the assumption that the road concerned has a zero gradient

Figure V5: Known 85thile speeds and the SSD requirement given in MfS

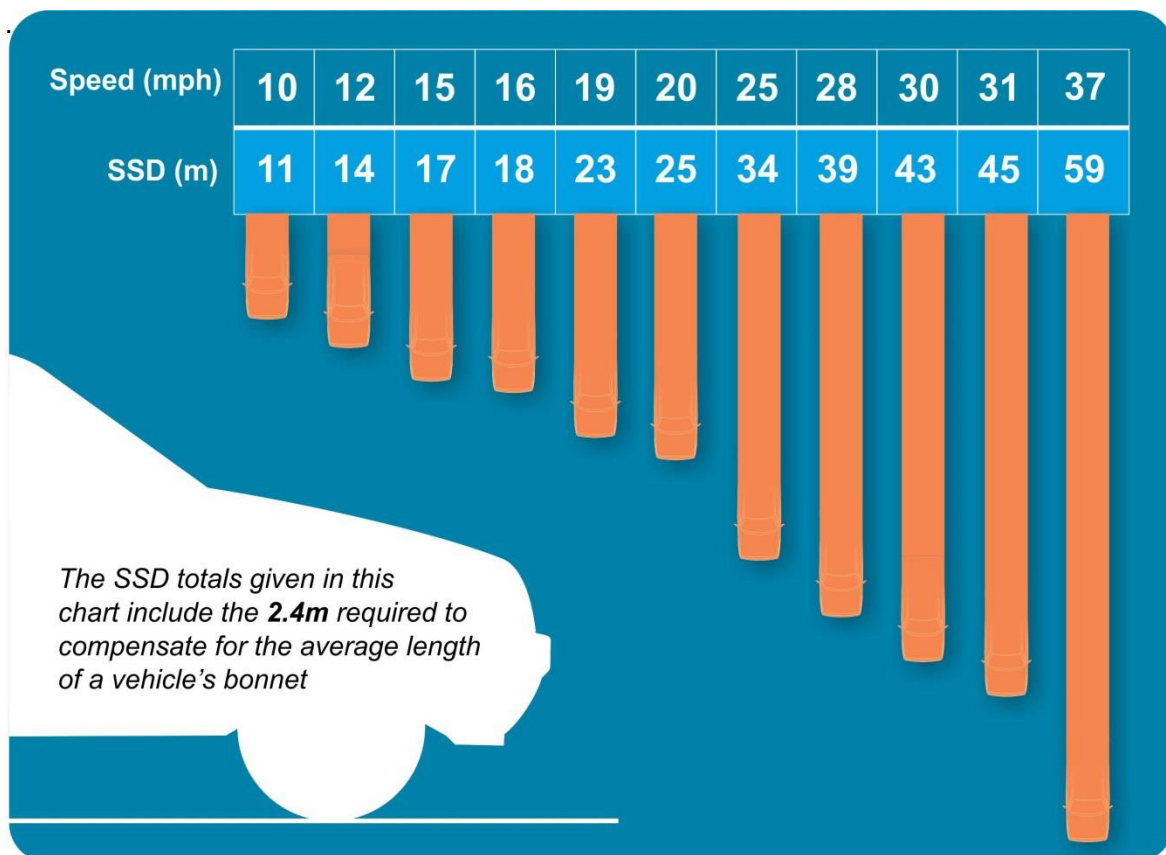

Existing roads with unknown 85th percentile speeds

On existing roads within the highway network, the new development will need to link in, preferably at a minimum of two locations. New junctions at those locations must be designed so that they are both efficient and appropriate to the traffic conditions that will be generated. At this stage consideration needs to be given to which source of data should be used to satisfy the visibility requirements for the new junctions.

It is always preferable to use actual recorded 85th percentile figures of traffic speeds on existing roads as they are the best method of generating an accurate design. Where actual speed data cannot be obtained then the next best method for identifying SSD is to use the existing road's 'design' speed. If this is not known, then the final method is to use the road's posted speed limit to determine SSD.

Figure V4 shows the SSD values that are to be applied to roads when no speed survey data is provided and the posted speed limit is used instead.

Speed surveys

Having access to the most comprehensive data possible is always preferred by the County Council as this will lead to the best and most accurate decision on what visibility distance is most appropriate for a section of carriageway.

It is for this reason that actual recorded speeds will always be desirable. Developers are encouraged to investigate the possibility of undertaking automatic speed surveys in order to provide this information in all cases regardless of the size of the development.

Speed Limit of Major Road (mph)	SSD (m)
20	27
30	60

Point at which it is recommended to change between using MfS and DMRB derived data

40	120
50	160
60	215
(mph) Speed Limit of Major Road	(m) SSD

Figure V4: SSD values to be applied using the road's posted speed limit

If significant gradients are proposed or in existence, then the visibility requirements will differ. In these instances designers will need to confirm the required visibility splay with the Highway Authority.

Applying gradients

Figure V6 below shows the SSD requirements for a new or existing road with a **20mph design speed** and where the severity of the gradient is known. A selection of gradients have been used to populate the Figure so as to provide a general indication of what the range in SSD values can be.

Although gradients have been included within the figure ranging from plus to minus 20%, the actual preferred maximum gradient for new estate roads in Cumbria is only 10%. Additional information relating to exceptions to this maximum can be found in the 'Gradient' section of this guide.

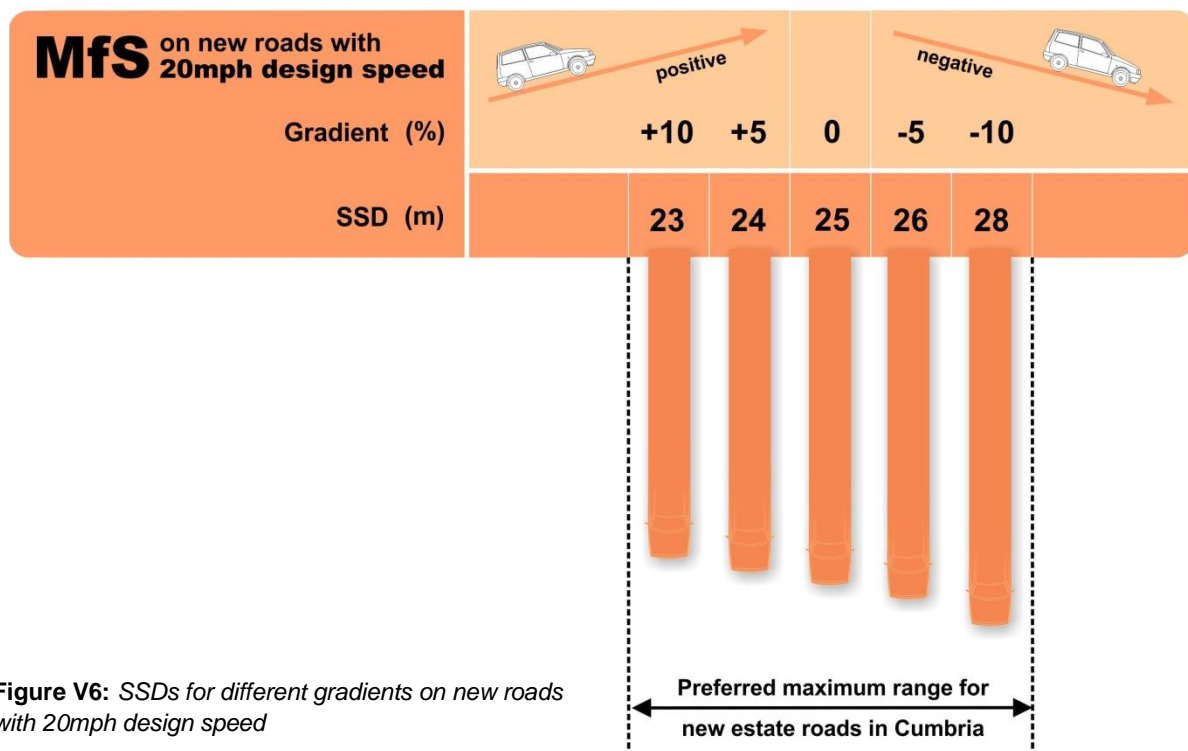

Please Note

If the specific gradient is known and it does not appear within figure V6 then that known gradient **should always** be used to generate the SSD, using the SSD equation in figure V2.

Cycleways & shared use facilities

Figure V7 shows the visibility envelope or span of unobstructed forward highway that a cyclist requires to satisfy their SSD figure. *Local Transport N 2/08 Cycle infrastructure Design* recommends SSDs for footways, cycle paths and equestrian routes which are all off-carriageway. The recommended distances follow the advice from MfS and are therefore different to the SSDs provided in DMRB 90/05. A distinction is made between the type of user relating to the cycle facility as a commuter route would expect speeds of up to 20mph whereas a local access route would expect the average speed of a cyclist to be 12mph. Further detail on what characteristics make up each of these route categories can be found in LTN 2/08.

A general approach when designing for each type of off-carriageway route is to keep gradients to a minimum wherever possible. If a gradient is too steep it will create difficulties for cyclists on ascent as they may lose grip and be forced into veering further into the carriageway putting them at risk of collision.

DMRB uses a maximum design speed of 30kph which can be reduced to 10kph over short distances. These speeds equate to minimum SSD values of 30m and 10m respectively. MfS has introduced an alternative selection which distinguishes between those

cycle speeds expected on a commuter route (20mph) compared with a local access route (12mph). The higher design speed of 20mph is comparable with the 19mph used by DMRB but the SSD is shorter than the latter.

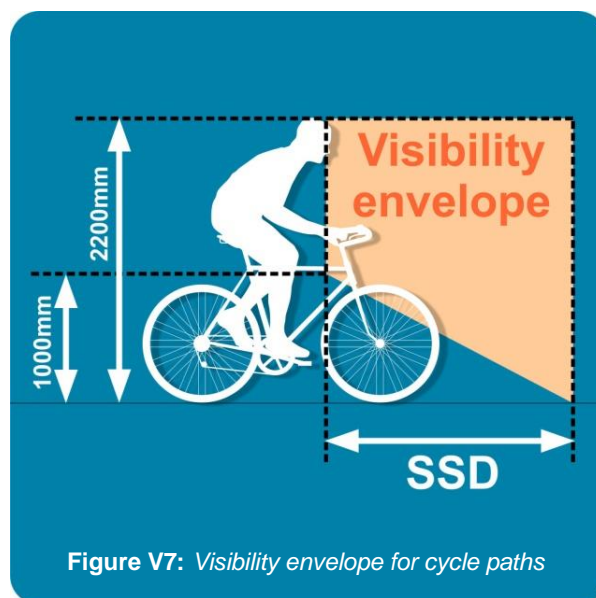
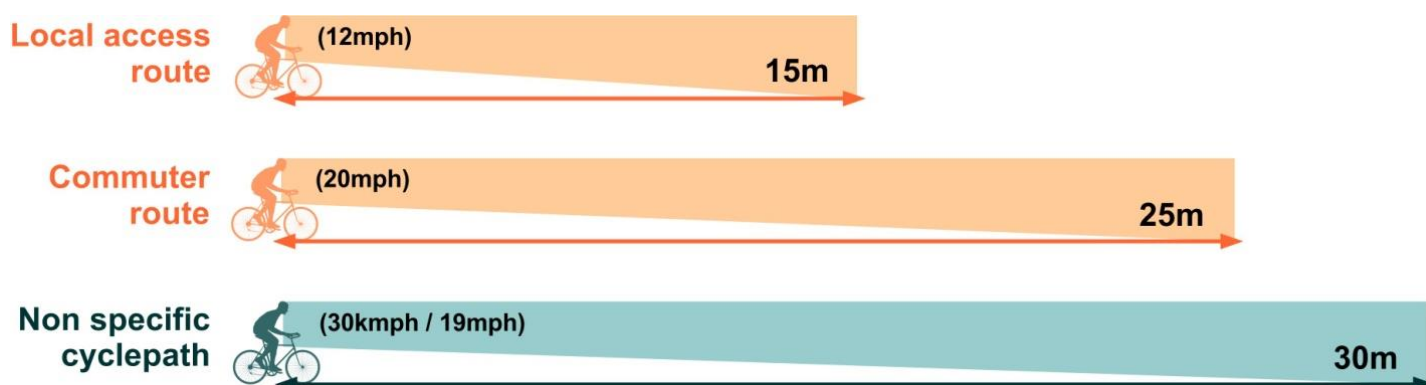

Figure V7: Visibility envelope for cycle paths

Designers are encouraged to assess all of available options in Figure V8 and choose whichever they believe to be the best fit, in respect of the cycle tracks purpose within the development. These Values of SSD over these minimums will mean a more comfortable and pleasant ride for cyclists and this should be a significant influence when designing the route.

Figure V8: Visibility envelope for cycle tracks



Visibility at a junction

Distance “y” is measured along the nearside kerbline of the major road to the left and to the right. This distance is measured from the central point of the minor road junction mouth in either direction.

If vehicles are not able to overtake on the major road, for instance if there is a central reservation or other barrier, then “y” can be adjusted for visibility to the left at the junction so that it can be measured to the centre line of the road. This means that the visibility splay to the left will need to take in less of the nearside verge or footway area.

There is the assumption that average speeds on existing roads will be reduced as a consequence of the introduction of a new development which links to that road. This is based on the understanding that an increase in activity which will occur at the new junctions will present a new risk to drivers and they will be less inclined to continue with the same confidence they have currently. The presence of ‘active frontages’ on a road will have a similar effect on traffic speed as activity increases and therefore as will risk.

Visibility through a bend

Figure V9 shows how the expanse of visibility which is needed when travelling through a bend in the carriageway. The shaded area of the diagram shows how much space must remain free of vertical obstructions (above 0.6m in height) to maintain the required field of vision.

Figure V9: how visibility through bend is determined

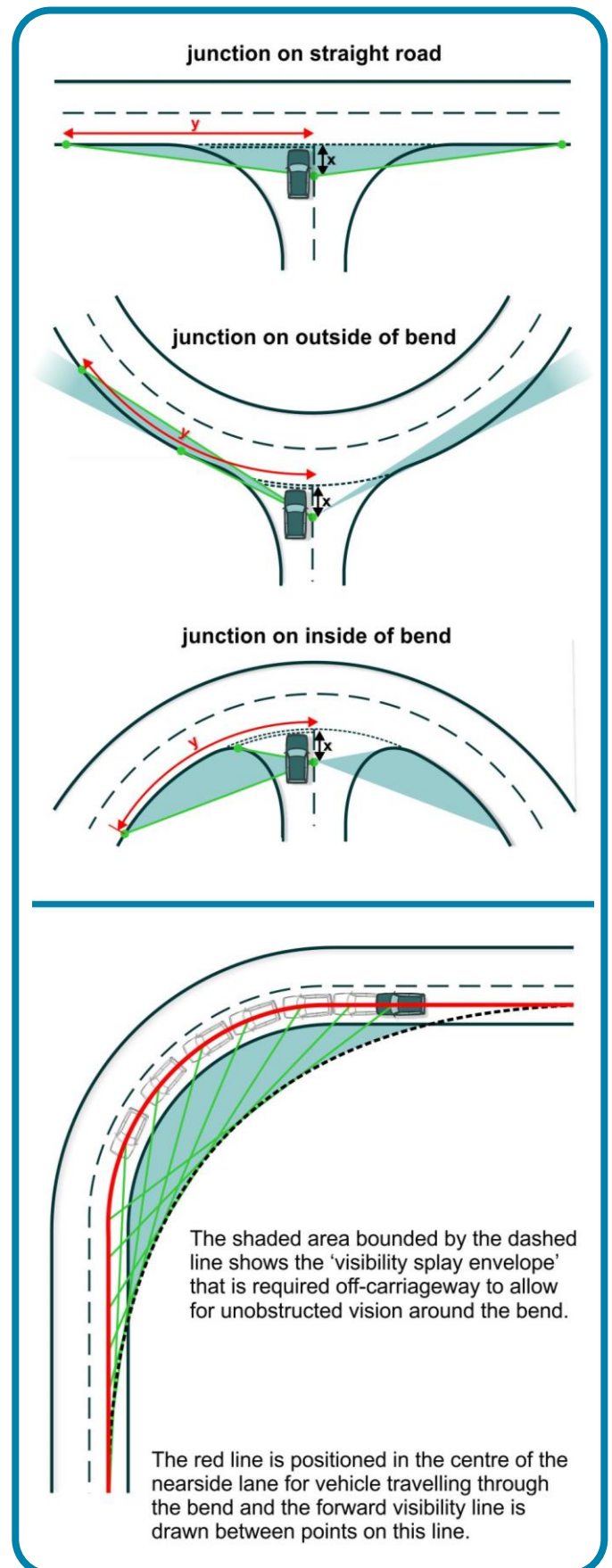

Barriers to visibility at junctions

Wherever possible, items of street furniture such as sign posts and lighting columns should only be installed at the rear of footways. If however this is not achievable and they need to be placed closer to the carriageway edge then in such situations, slender infrastructure such as posts and columns will not generally be judged to be an impairment to visibility. If the placement of any of these items in combination leads to a situation where a barrier is created and views are blocked then such a happening would not be considered acceptable.

Figure V10 demonstrates this cumulative effect where each feature is working as a blocker to visibility for emerging traffic from the side road.



Figure V10: visual obstructions at junctions

Visibility at private accesses

Although a private access road or drive is not adoptable by the Highway Authority, how they connect to the highway is of extreme importance to ensure safety and maintain the efficiency of that highway. The type of arrangement used at the transition point between public highway and a private access road or drive is dependent on a number of influencing factors. These can include the existing geometry of the site, existing landscaping and the design character of the new dwelling.

- Is the access obvious?
- Can it be recognised by approaching traffic and what are the clues that inform people of its presence?

So that vehicles exiting the private surface onto the publicly maintained highway can see or be seen by pedestrians and other vehicles sufficient visibility must be provided. For an emerging vehicle which moves out and crosses over a footway/cycle track, a minimum splay of 2m by 2m is recommended however if there is no footway or verge present the visibility requirements will be that of a normal junction.

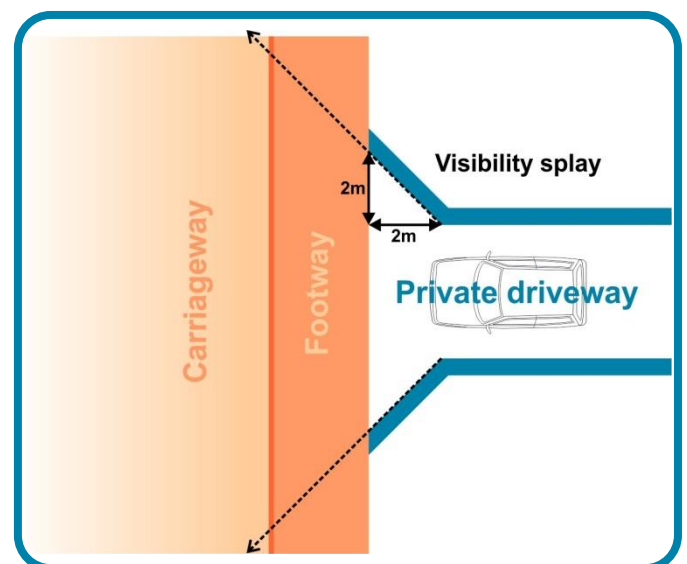

Figure V11: Visibility splay at a private access when a footway is present

If restricted visibility is to be used as a speed reduction measure and 'y' distances are being considered that fall short of those provided in this section, then approval must be sought from Cumbria County Council's Flood & Development Management Team.

Junction spacing

If the distance between the two junctions is too short, then vehicles positioned at the junction head will act as a visual obstruction to vehicles waiting at the other junction. For this reason, a minimum spacing is often required, particularly on roads where speeds are likely to be in excess of 20mph. Figure V12 shows the recommended spacing for junctions on a primary road and for a secondary road. These street types will require a minimum junction spacing of 25m which is SSD value for a design speed of 20mph.

All other types of road within the development are not provided with minimum spacing information with the purpose of this being so that layout designs are not constrained and designers have more freedom to design spaces where traffic speeds are low.

When the new residential street connects with the existing highway network it will be necessary to account for the appropriate junction separation required by the traffic speed on the major road.

Considering large vehicles

It is important to design roads so that large vehicles can use them from time to time, such as pantechnicons and refuse vehicles. This will require the road to be capable of allowing the swept path of such vehicles (possibly through the provision of strengthened footways on bends).

If large vehicles are to account for a significant portion of traffic flows on a road then SSDs will need to be adjusted accordingly, 5% of the total traffic flow is generally considered to be an appropriate threshold.

Advice on designing for large vehicles is given in Part 2 of the Design Guide.

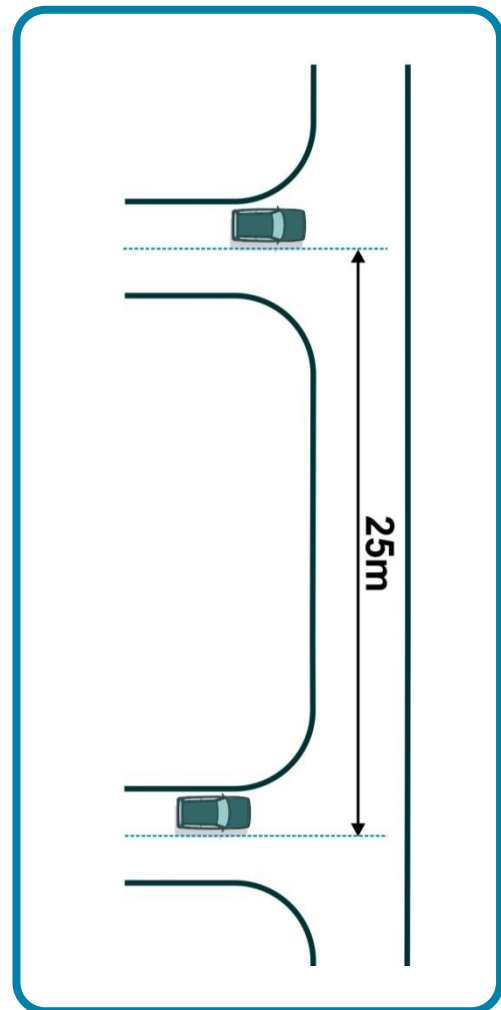

Figure V12: junction spacing for primary and secondary roads in new residential developments

Chapter C.

Carriageway widths

MfS states that the width of the carriageway must be appropriate for the context of the street and gives the following criteria as factors to consider:

- Volume of traffic
- Modes of traffic
- Design speed

It is anticipated that the flow of traffic will not have a significant impact on the selection of a carriageway width as flows in residential developments are expected to be low.

The type of vehicle that requires access to the carriageway will be a more influential factor in terms of what needs to be accommodated and what can be done to permit this access whilst maintaining an environment of low speeds and pedestrian freedom of movement.

The narrower the width of a carriageway within residential developments then the greater the

opportunity for controlling traffic speeds within those developments.

Where it can be demonstrated that the overall layout of the carriageway within a scheme will control traffic speed then although still important, there is however less of an absolute requirement for width to play as vital a role in the design.

Where it cannot be clearly demonstrated that the overall layout will have this calming effect on traffic the minimum recommended widths should remain as a requirement.

Any final decision on carriageway widths will be dependent on a swept path analysis of various expected vehicles on the road.

Future proofing

In locations where future expansion could be incorporated into a new development's road network then likely primary roads should be designed sufficiently such that they can be adapted to cope with additional traffic. Any alterations that are required to accomplish this should be low cost and cause minimal disruption to the existing community.

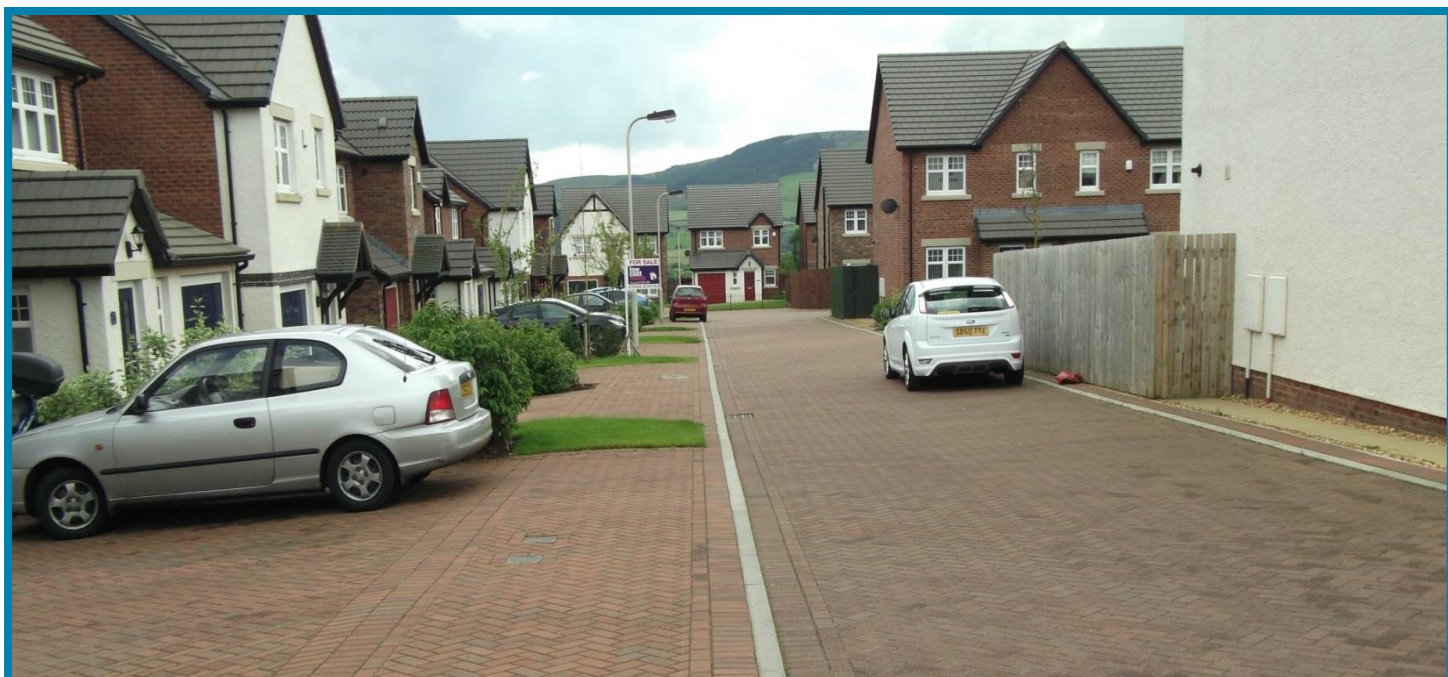

Typical vehicle widths

Figure CW1 below sets out the *average* widths expected for vehicles which are likely to require access on residential streets.





			dynamic envelope
Bicycle (mounted)		750mm	1000mm
Bicycle (being pushed)			1100mm
Light vehicle (inc wing mirrors)			1950mm
Fire Appliance (not including wing mirrors)			2600mm
Large service vehicle			2600mm
Public service vehicle			2600mm
Rigid body lorry (inc wing mirrors)			3050mm

Figure CW1: Typical vehicle widths

Typical carriageway widths

The above examples are all typical widths of carriageway that are already used in residential developments throughout the county and the country. The diagrams are indicative of how suitable each width would be for serving particular types of street or road. This information should be used by developers when selecting proposed widths for their new developments considering contributory factors such as the types of vehicle expected, traffic flows and speeds.

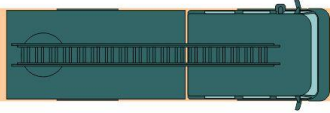
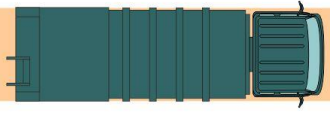
Footways

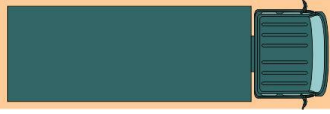
The general requirement of a footway is that it should be wide enough to allow people to pass one another when travelling in opposite

directions. Footways are usually employed as the area for siting underground services and as such should be wide enough to accommodate the various service infrastructure. 2000mm is considered adequate for this purpose (arrangement of underground utilities is given in the "Utility Services" chapter of this guide)

A 1200mm footway width is only permissible where;

- the flow of pedestrians will be very low; or
- it is only for a short length with wider footways at either end in order to pass a pinch point; or
- the width is not further obstructed by road lighting columns or furniture

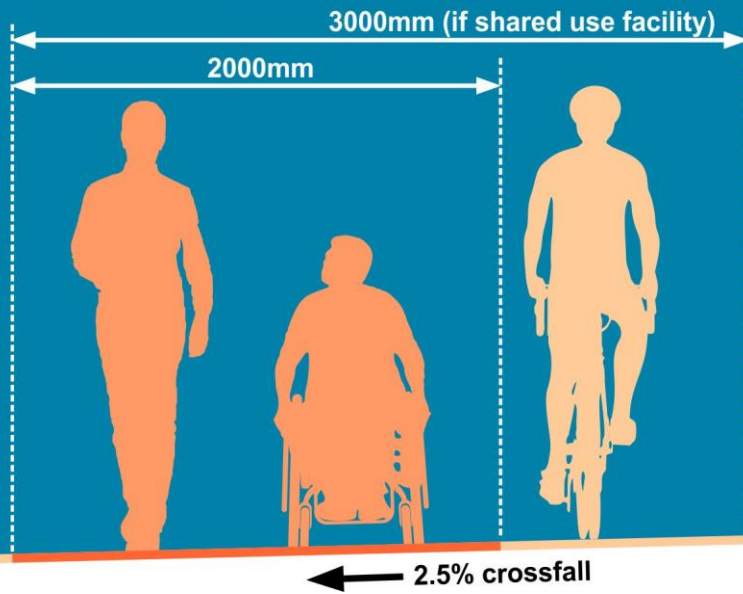

FigureCW2: Preferred minimum width for footways

Cycle Tracks

The recommended width for an off-carriageway cycle track is 3000mm which is sufficient to allow for the integration of pedestrian facilities. This width allows for a relatively comfortable shared environment where pedestrians are not intimidated by cyclists approaching and passing too closely. An absolute minimum width of 1500mm may be used but only in cases where factors such as site topography or other width impacting factor has an effect on the design. At 1500mm, two cyclists can still pass by one another but only with caution. In these situations, there should be sufficient verge width to allow handlebars and pedal positions to overhang and there must not be any vertical feature abutting the cycle track which could be struck by a cyclist on the route.

The effective width of a cyclist is wider when they are moving than when they are stationary. This effect is referred to as the 'dynamic envelope' and is produced by the body as it tries to apply force on the pedals for forward movement. 1000mm is the average width which should be assumed for this envelope. Gradient severity of the carriageway is likely to also impact on the lateral movement of cyclists on the highway

and is explored more in the 'Gradients' section of this guide.

Marked cycle lanes on new residential streets are not considered to be necessary as design speeds are low and the design should promote an inclusive environment where motor vehicles and cycles can mix with a low level of risk.

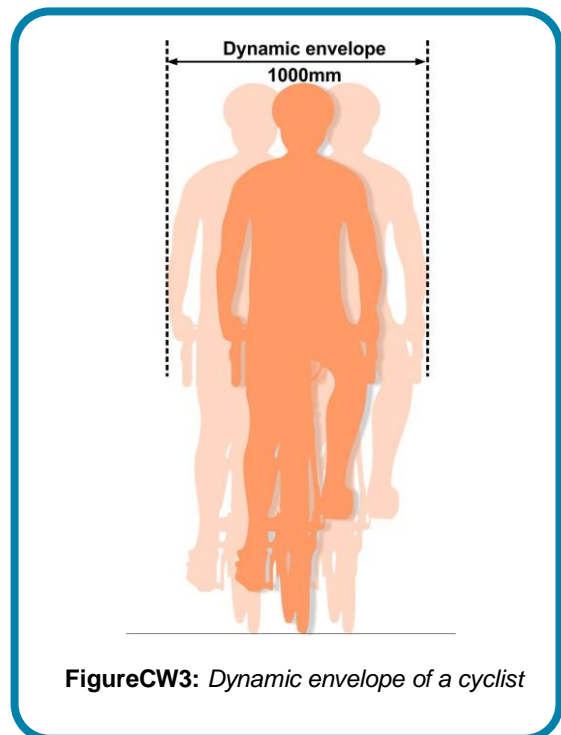

FigureCW3: Dynamic envelope of a cyclist

Roads

It is of great importance that developers are realistic when selecting a carriageway width and the choice which has been made is fit for purpose. Carriageway widths that are inappropriate for the type of road user, volume of traffic and speed will encounter issues that will cause unnecessary hardship for road users and residents in general and will almost certainly lead to remedial works being required.

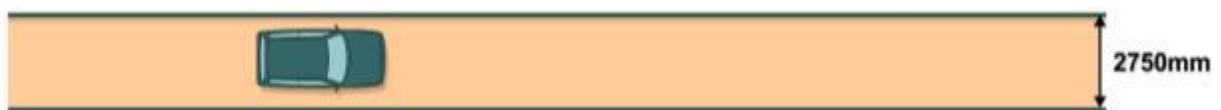

2750mm is the minimum permissible width of motor vehicle carrying highway that could be adopted by the Highway Authority. This width would be suited to short sections of carriageway where only one vehicle can be accommodated at any one time. Passing places may be required if the length of carriageway will cause vehicles into making excessive reversing manoeuvres.

Generally, this width is only used for private accesses and driveways which are not within the Highway Authority's remit for adoption. Even where this is the case, the requirement for fire appliances to have working width of 3700mm (see previous in this chapter) needs to be catered for so it may not be possible to apply a constant width of 2750mm regardless.

This width does not allow for the overtaking of cyclists which forces vehicles to remain behind until the cyclists allows the vehicle to pass or the road width increases.



3700mm is sufficient to allow light vehicles to avoid conflict with cyclists but does require additional carriageway width when confronting any other vehicle including other light vehicles. Passing places will be required to allow for the two-way movement of light vehicles and these places should be designed so as not to encourage parking within them.

LTN 2/08 indicates that for cars passing at 20mph, cyclists will require the carriageway to have a minimum width of 3800mm. This guide generally requires traffic to be travelling at speeds below 20mph so the preferred standard of 3700mm is considered appropriate for this task whilst still allowing safe movement for cyclists.



A carriageway width of **4100mm** will allow light vehicles such as cars and vans to pass each other without the need to give way but only at reduced speeds for the sake of comfort. Larger vehicles such as refuse service vehicles will require additional width to allow for transition. This additional width may be created through the use of passing places or by restricting the length of carriageway which uses this width.



A carriageway width of **4800mm** will allow for cars and HGVs to pass one another without the need to give way but only at reduced speeds for the sake of comfort. Large vehicles will not be able to pass each other without giving way and will require additional width at some points to accomplish this.

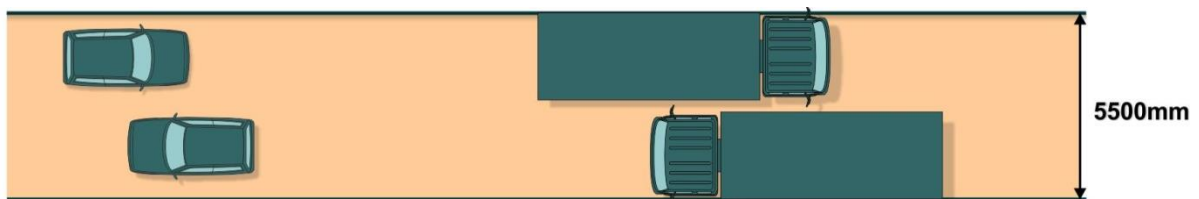

A carriageway width of **5500mm** will generally allow for all vehicles that are expected to use a residential development to pass one another without the need to give way. Larger vehicles will still have to approach one another with caution and at bends in the carriageway it may also be necessary for one to give way to the other.

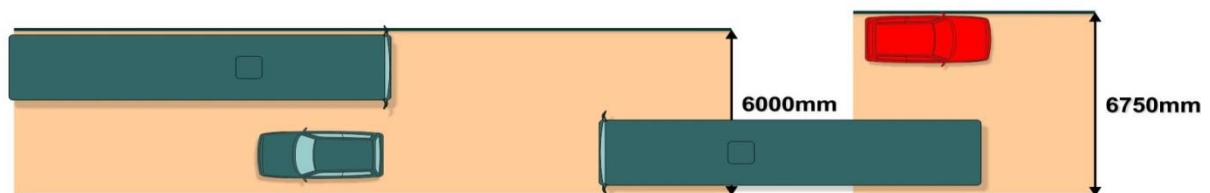

A carriageway width of **6000mm** is suitable for use on a bus service route as there should be no conflict between oncoming vehicles. If on-street parking is to be encountered (represented by red vehicle in above diagram) then a width of 6750mm is required which will allow ample room for vehicles to overtake stationary vehicles at bus stops without creating a safety concern. This is the maximum permissible carriageway width within a new residential development.

The 'Road hierarchy' chapter of this guide gives recommended widths for carriageways serving a variety of road types and should be seen as a starting point for design decisions concerning width. Any departures away from those recommendations will need to be justified by the provision of evidence to persuade that the road will still function efficiently.

Entry points to any road with two-way traffic should be wide enough at that point to allow two cars to pass by one another.

Access by emergency services

There are a variety of widths for fire appliances being used in the UK, however a typical vehicle width of 2550mm is acceptable for assessment purposes. This width does not take into account the wing mirrors of the vehicle. It is therefore important that this width can be kept free from obstructions at all times so that access can be provided to residential properties.

This does not require that the carriageway design must permit two vehicles to pass by one another at all points, rather that where carriageway width is only one lane wide, parking must be discouraged.

There is a stated desired minimum width between kerbs of 3.7m (*Association of Chief Fire Officers*) to allow for operating space at a scene.

It is a regulation within the UK that a fire appliance must be able to access to a point within 45m of any dwelling, although this access does not have to be provided by the carriageway.

Footways or Cycle Tracks which are constructed to a sufficient width and strength may be considered as suitable emergency vehicle access (EVA) routes which fire appliances may utilise to achieve the 45m access arrangement to a dwelling.

Restricting the length of the narrow section of carriageway introduces a speed reduction

feature into the development whilst still allowing access to the maximum required width vehicle.

It is imperative that developers demonstrate the arrangements that are in place for emergency vehicle access in the event of closures on roads within the development **as well as access to fire hydrants**. Permeability within the design should allow alternate routes in such situations.

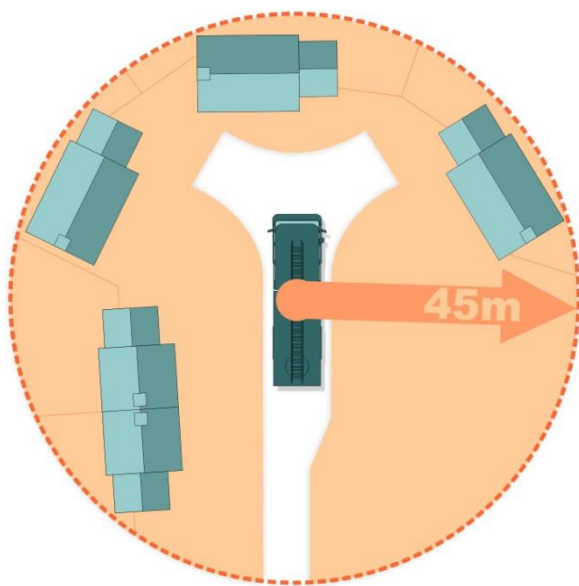

Figure CW4:
access requirement for a fire appliance

Access requirements for emergency vehicles

- Turning facilities will be required if the road is a dead end and the distance that the appliance would need to reverse for exceeds 20m
- A fire appliance must be able to access any point within a dwelling from a maximum distance of 45m
- A width of 3.7m between kerbs is required for an appliance to operate at an incident
- 2.75m carriageway width is permissible to allow access but only for short distances

Carriageway width on a bend

To allow for adequate swept paths of large vehicles in residential developments there is likely to be a need to increase carriageway width on some road bends. This will particularly be the case on public service vehicle routes and where refuse vehicles require access. It is likely that the need for large vehicles such as HGVs to pass one another on a bend in a residential area will be minimal as their numbers are expected to be low. In situations where this conflict does occur it would be expected that one vehicle would give way to the other.

Figure CW5 shows the additional widths which are typically needed on top of the normal carriageway width.

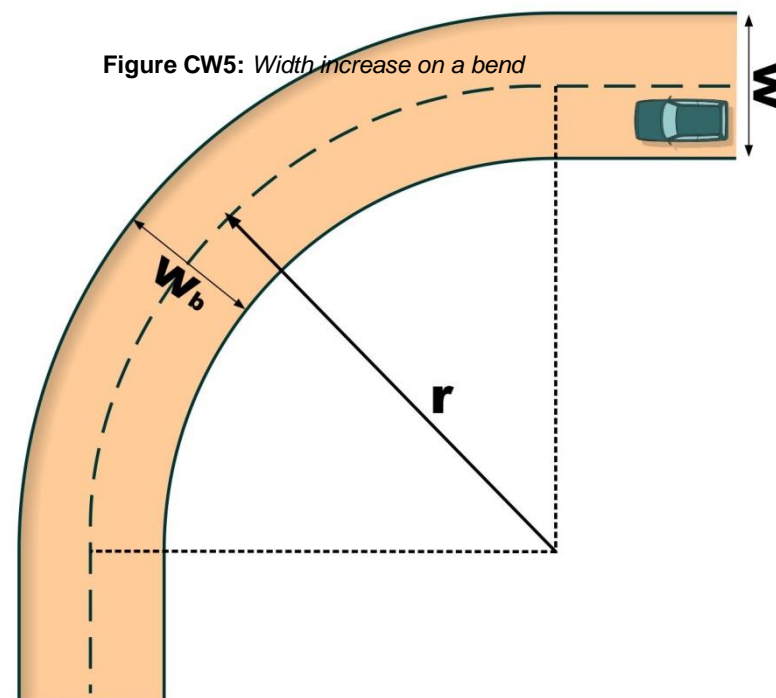

Figure CW5: Width increase on a bend

Centre-line radius (m) r	20	30	40	50	60	80
Width on bend (m) W_b	W+0.6	W+0.4	W+0.35	W+0.25	W+0.20	W+0.15

Chapter D. Junctions & radii

These transition points between roads should be designed such that the road user is made aware if a change in behaviour is required such as when entering a shared surface street from a primary road.

The choice of junction arrangement used for residential developments can either help to

enhance the character of the area or work against this aim and have a detrimental effect on the design's effectiveness.

MfS lists a variety of junction options which could be utilised by developers to provide the best solution to a transition area. Figure JR1 shows those options given in MfS and have been ordered so that the angular, geometric layout can be compared against more organic amorphic examples.

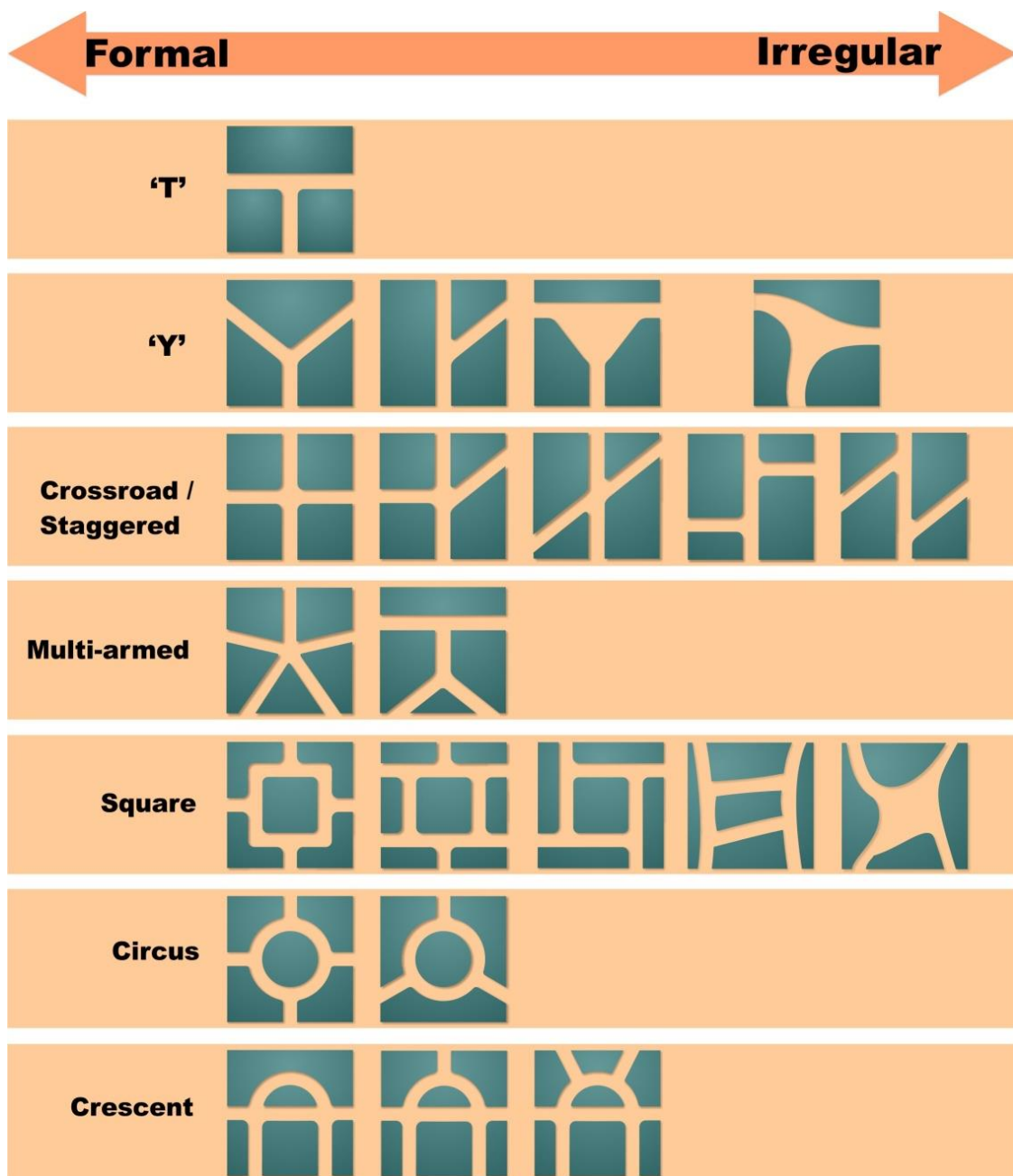

Figure JR1: Various junction layouts which are available

Although we can see a range of angles between roads in Figure JR1, it is important to consider how motorists position their vehicles at the junction head. If we examine the Crossroads / Staggered section, the option to the far right may prove troublesome for vehicles pulling into the side minor roads from the major road. This is due to the swept path that would be required as well as the potential for another vehicle to be on the minor road access of the junction waiting to emerge – a conflict could therefore easily occur.

It is generally recommended that roads should meet at a right angle or as close to this as is possible.

For roads in residential developments, wide sweeping bends at junctions are generally not essential as only larger vehicles will need this additional swept path to complete their turning manoeuvres. It is of course the case that these vehicles will periodically require access (e.g. refuse vehicles, pantechnicons) so footways located on tight corners should be constructed to cope with any necessary mounting by such vehicles.

Although Figure JR2 below shows the interrelationship between each of the road types identified for residential developments. The diagram shows what corner radii are appropriate between the road types.

Figure JR2: Recommended radii for use at junctions in residential developments

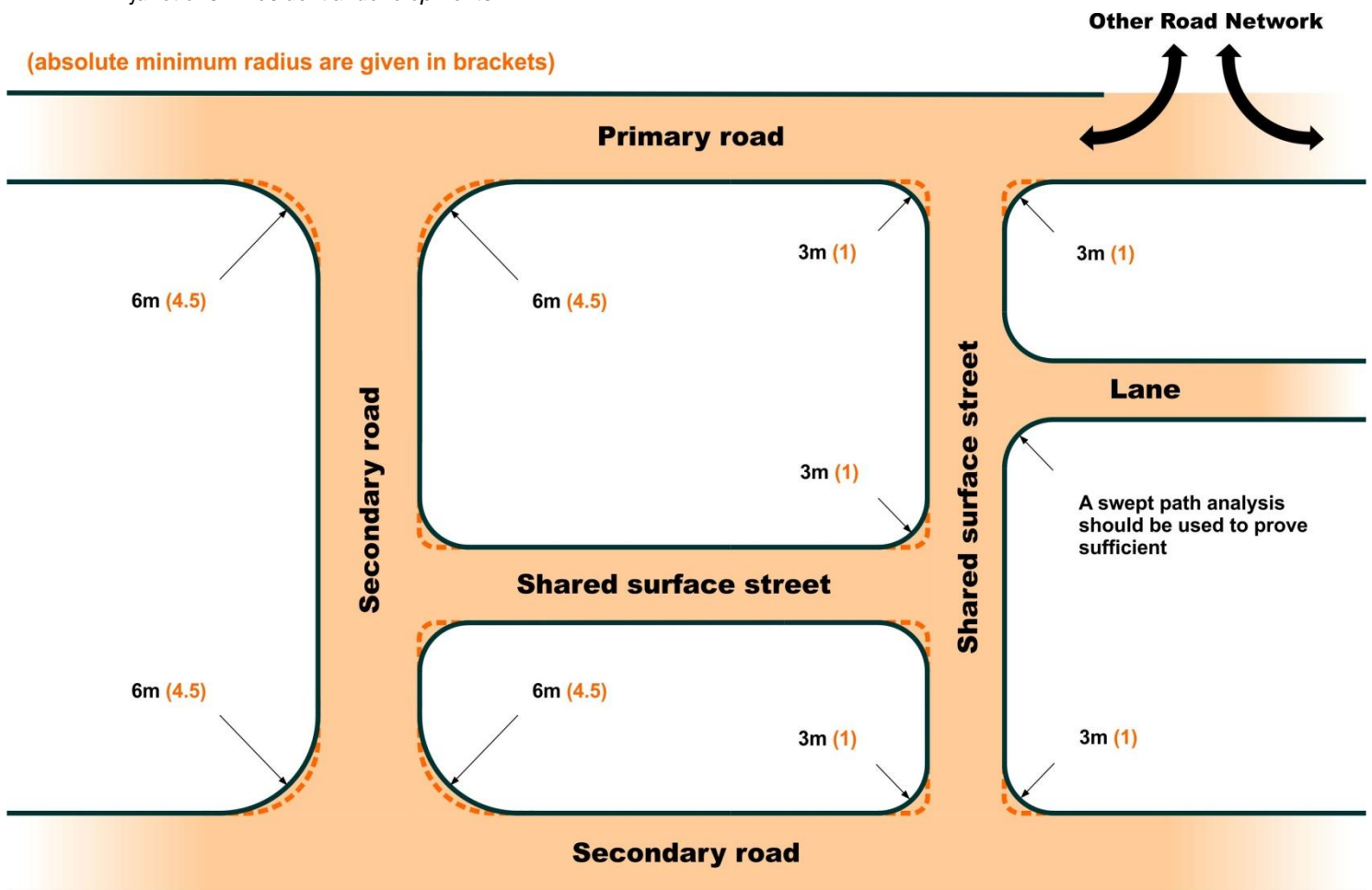

NB All radii chosen for junctions will need to be verified via swept path analysis

Benefits of using minimum radii

Speed reduction

Figure JR3 shows how speed is affected by the radii of the bend. The top illustration shows how a tight radius of 1m would force a vehicle to slow down in order to negotiate the turn. The illustration beneath shows that through the use of a longer radius there is less of an impact on the turning vehicle's speed.

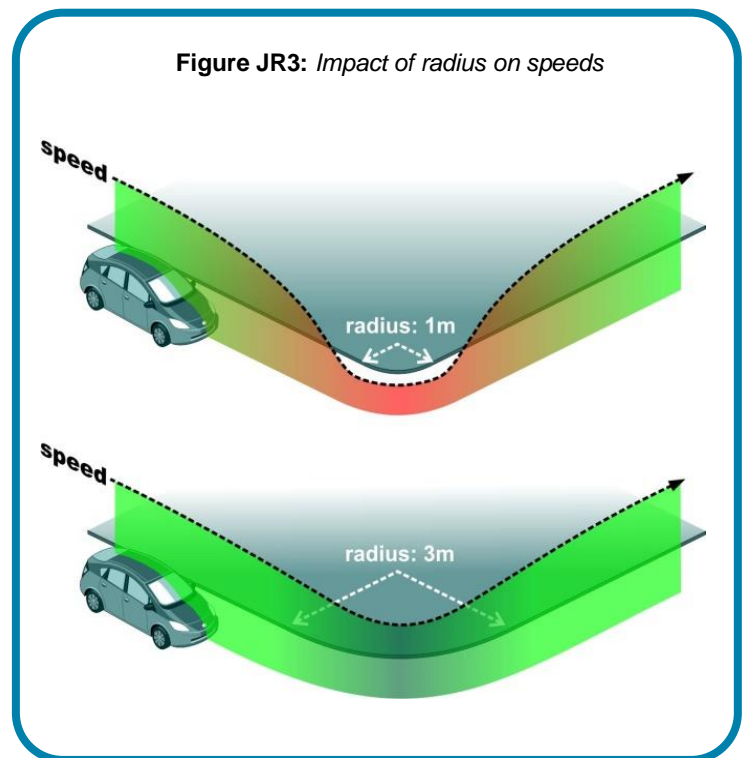

Pedestrian safety

An additional positive outcome of using smaller radii on junction corners is the opportunity to maintain pedestrian desire lines where footways are present. By providing the crossing point close to the junction, the amount of road space that a pedestrian needs to scan prior to crossing is also reduced. Figure JR4 demonstrates this principle with the higher illustration showing a wide sweeping corner requiring pedestrians to look backwards for a greater distance than that needed by the tighter corner in the bottom illustration.

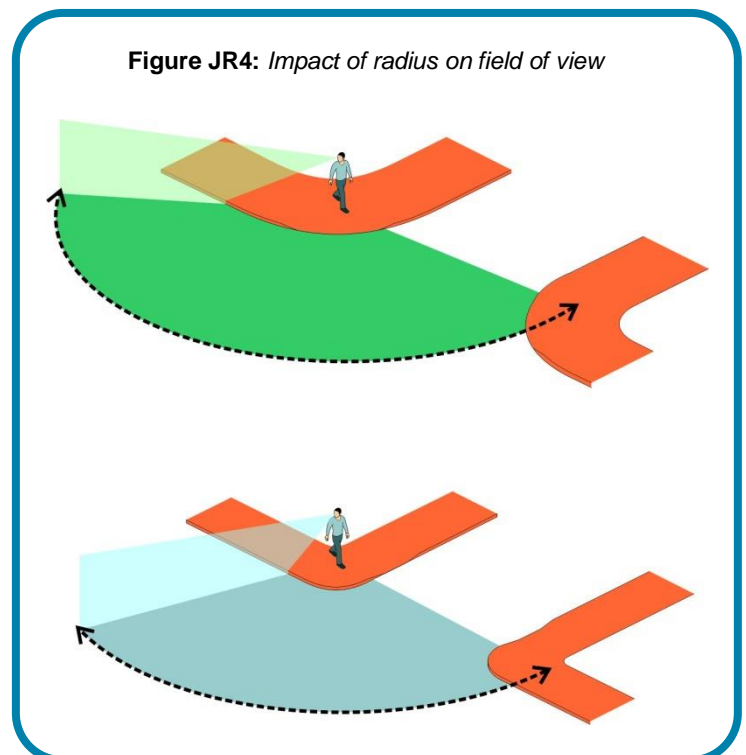

Pedestrian ease of movement

A comparison of the two examples in Figure JR5 shows how a tighter radius, seen in the top illustration, will lead to only a slight shift in movement for pedestrians wishing to cross over the junction mouth. This deflection can be avoided entirely depending on how wide the footway is on approach to the crossing point.

The lower of these two examples shows a larger radius and the affect this can have on the position of pedestrian crossing facilities and the significant departure from the desire line that is required.

Pedestrians should have the option to cross the road on the desire line itself, regardless of whether there are dropped kerbs at that location. To accommodate this movement, the placement of road furniture and other obstructions need to be considered carefully.

Overrun areas

The use of deliberately designed and correctly constructed overrun areas within a residential development can be beneficial in controlling vehicle speeds making transitions between roads. Junctions can be visually narrowed encouraging vehicles to enter/exit with caution as they are pushed toward the centre of the carriageway which introduces the potential of conflict with an oncoming vehicle. Through the selection of appropriate materials for the overrun area the visual encouragement is backed up by the discomfort that is experienced through vibrations if the area is driven over.

MfS states that the use of these overrun areas should generally be avoided in residential and mixed-use streets due to concerns over their impact on cyclists, pedestrian desire lines and

their visual intrusiveness. The impact that noise will have on residents will also need to be considered as the resulting noise pollution from these vibrations may prove to be a nuisance.

Whilst these factors are all important considerations they should **all** be negated if the developer sufficiently addresses the concerns as part of the design process.

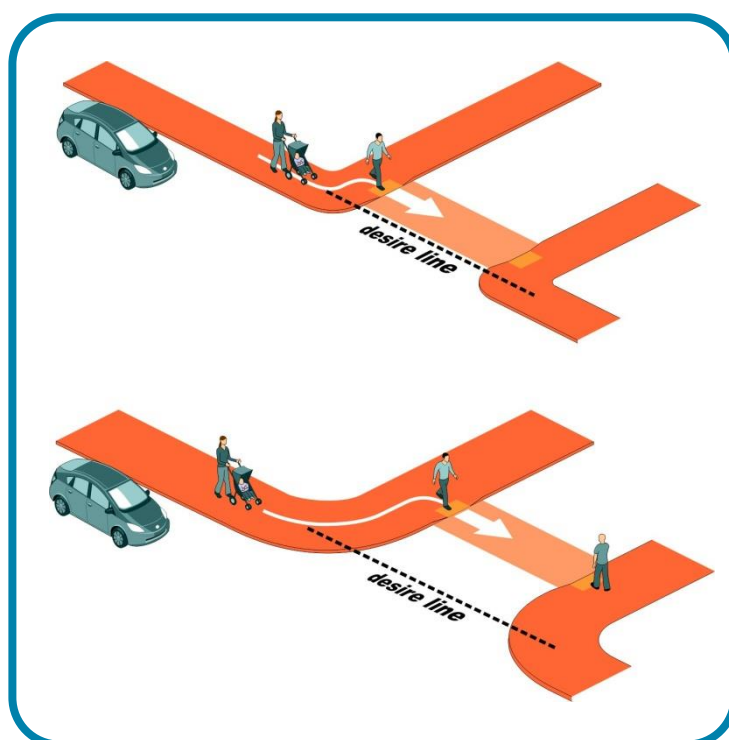

Figure JR5: *Impact of radius on desire lines*

Chapter E. Turning areas

The requirement for turning heads within residential developments should be limited as generally the design of the layout would be expected to be permeable and hence reduce the need for turning facilities. The Highway Authority wishes to minimise the number of reversing manoeuvres in the road, which includes reversing into the highway from a private access and performing U-turns or multiple point turns.

Reversing for long distances presents more of a risk than if vehicles are able to travel in a forward gear. This risk is particularly high when large vehicles are required to reverse in busy pedestrian environments. These larger vehicles are subject to more blind spots than a typical small private motor vehicle and as such there is an increased chance of collisions occurring.

Any place where it would be unsafe or potentially damaging for a vehicle to attempt to turn around within the carriageway will also qualify as exceptional and therefore warrant a turning facility.

The types of vehicles which would be expected to use the turning area need to be assessed prior to a decision being made on the design. The likelihood of large articulated vehicles using the space needs to be balanced against how regular that occurrence would be.

Pantechnicons will be the largest vehicle that most residential streets will have to accommodate through the road width and geometry. However, as these vehicles will generally only require occasional access to a residential street it is refuse vehicles that will be the dominant consideration when assessing road layout. Refuse vehicles will require access on average once a week (general waste and green waste collections). It is imperative that these collection wagons are comprehensively designed for and that the maximum reversing distance for these vehicles, of 12m, is fully respected.

Any area that is designated for turning vehicles must remain free from parked vehicles and other carriageway obstructions. To ensure this can be achieved, adequate parking provision must be made available to residents in suitable locations.

Figure T1: *Maximum reversing distances for refuse vehicle*

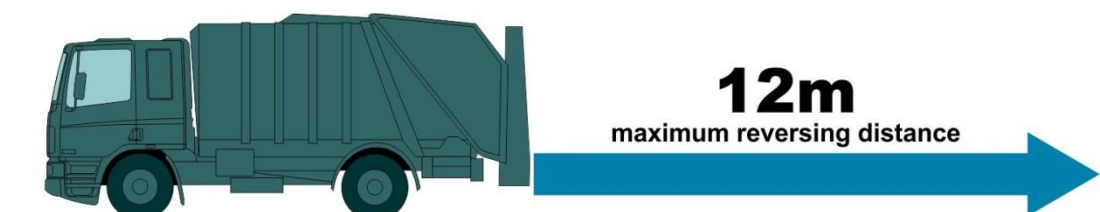

Turning area layouts

The diagrams in Figure T2 show traditional layouts for turning areas at dead ends within residential developments. The red outline shown on the diagrams demonstrate how the geometry of the turning areas could be adapted into an amorphous shape which may be better suited to residential areas due to its informality, but this will depend upon the character of road which is envisaged by the designer.

Any shape may be used as long as that shape is able to contain the red line boundary shown on the diagrams in Figure T2. Those red lines represent the swept path requirements for the turning manoeuvre of the largest anticipated vehicle using that area.

A 'square' or 'circle' could, for instance, be chosen as options just so long as the required turning area is available within those spaces. There will be no need to visually define the extents of that turning head as long as features are present which keep the area clear of parking and road furniture.

Designs should always consider how parking may affect turning manoeuvres and attempt to design out the issue or at least minimise the impact. Signing and any associated prohibition road markings to prevent parking in these areas will not be considered as a viable solution and should only ever be used as a last resort.

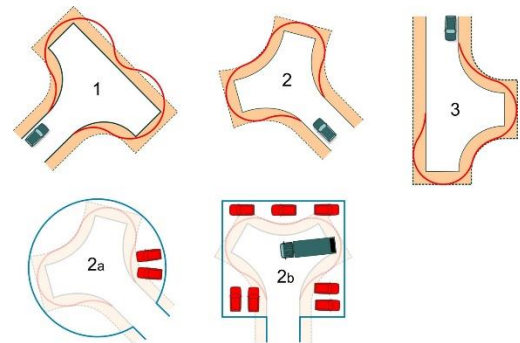
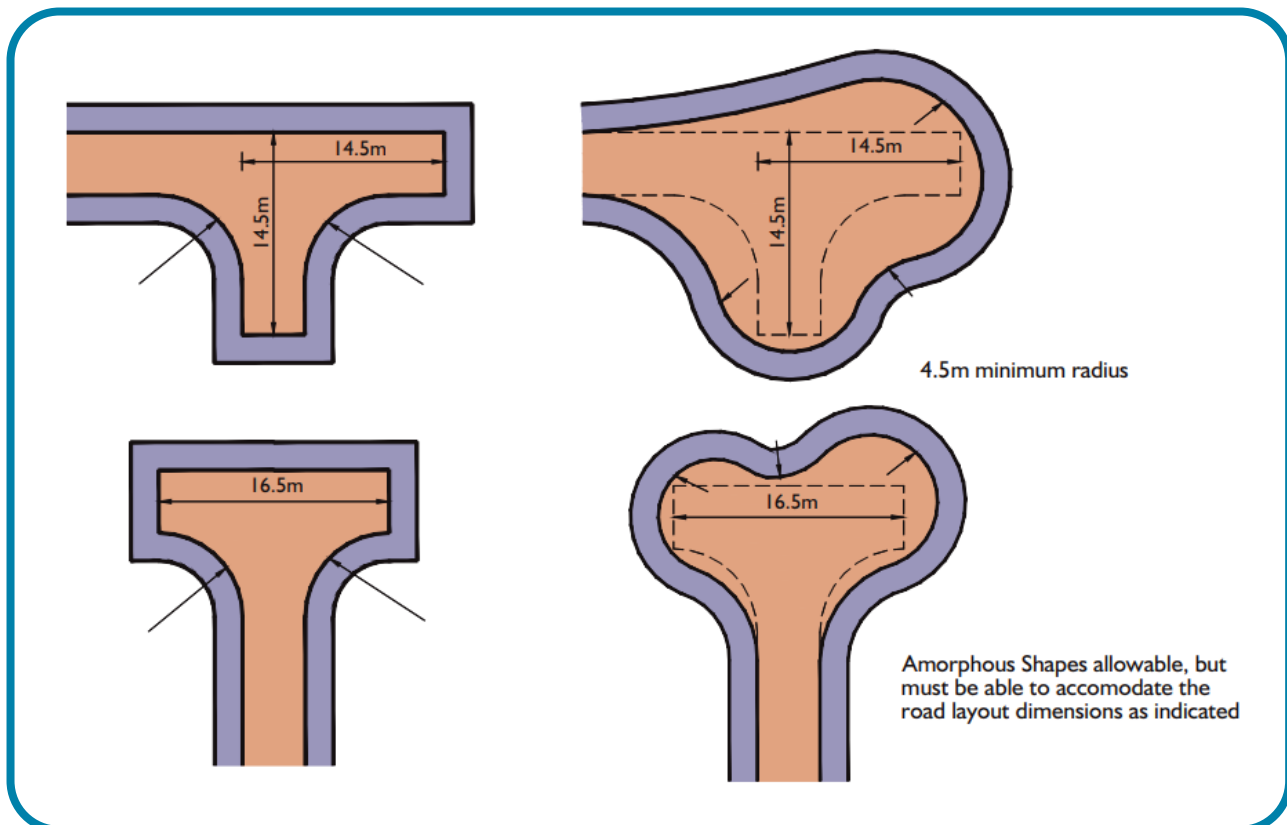

Figure T2: Turning head arrangements:

Diagrams 2a and 2b demonstrate how the turning area from Diagram 2 can be accommodated without the need for visual demarcation.



Refuse vehicle requirements

Refuse vehicles will be regular visitors to residential streets and as such require specific consideration in terms of accommodating them into the design of the road. The design should always seek to avoid the need for these vehicles to reverse but where this is not possible and a turning area is required, this area must allow the refuse vehicle to turn around in maximum of 3 movements.

The maximum distance that a resident will be expected to transport their refuse receptacle from their property is 30m. If the adopted highway edge (carriageway, not footway) is within this distance then there will be no need for a refuse vehicle to enter that road.

If the distance between the highway and the furthest dwelling on a road is greater than 30m then a suitable location will be needed where residents can communally gather their refuse so it can be collected. Figure T3 shows the maximum distances that are permitted for operatives to transfer different receptacles to the collection vehicle.

These factors in combination mean that a turning area must be provided on a cul-de-sac if the furthest dwelling on that road is more than 45m (30m + 15m for two wheeled bins) from the major road. This requirement applies to both adopted and unadopted side streets.

Developers are encouraged to consider the use of small areas of hardstanding within their designs that can be used for the placement of bins on collection days. The provision of these areas is desired so that footways and shared surfaces can remain clear of obstructions allowing normal flows to continue.

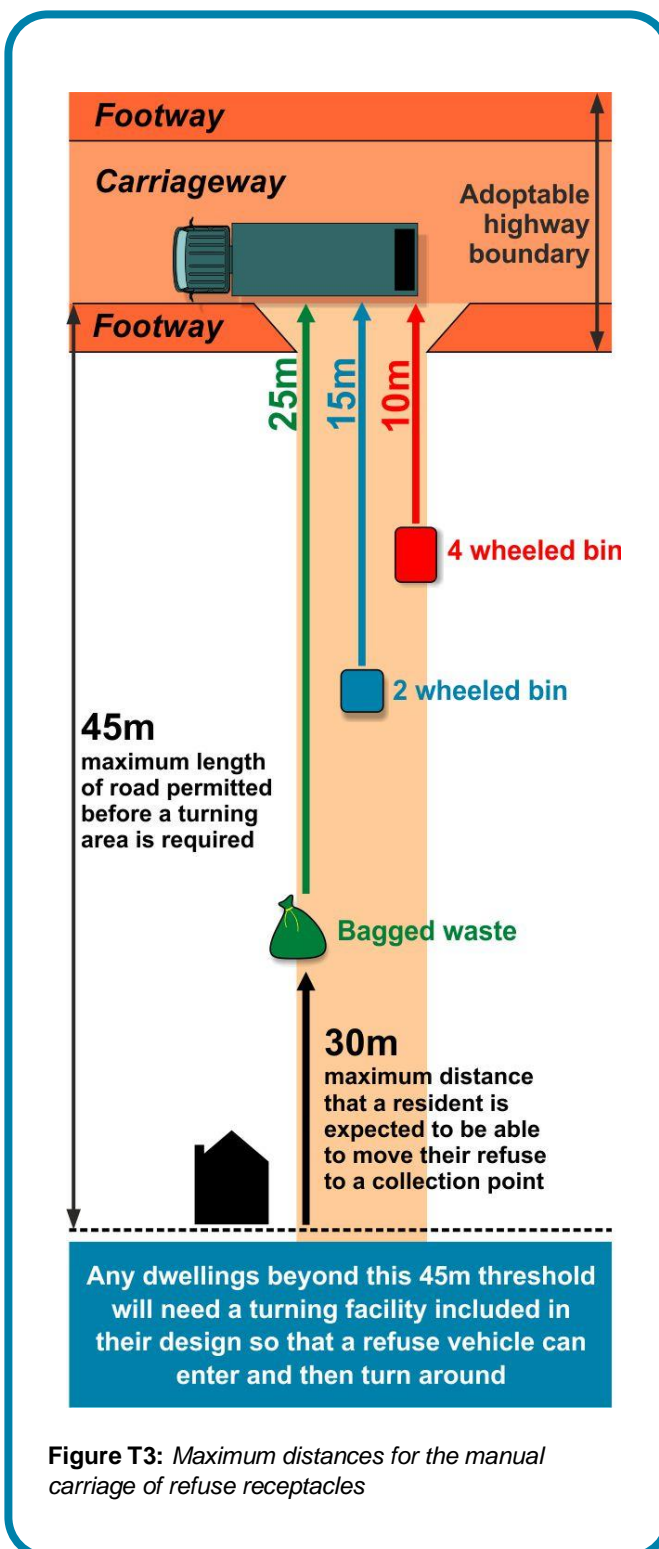

Figure T3: Maximum distances for the manual carriage of refuse receptacles

Chapter F. Speed management

A road's speed limit is not necessarily an indication of the appropriate speed at which to drive. It is the responsibility of drivers to travel within the speed limit but at a speed suited to the conditions. The design speed for new streets that serve residential areas is to be a maximum of 20mph. To ensure that the maximum design speed is viable and appropriate it may be necessary to introduce measures which will aid in keeping speeds low.

The key objectives for speed management in new residential streets are:

- Maximum design speed - 20mph
- Speeds should be self-enforcing
- Drivers need to be convinced that to proceed at sub 20mph is best. This can be achieved by instilling doubt and demanding higher levels of concentration.
- Design out segregation of travel modes so that speed is kept low.
- No vertical deflections are to be used unless they can serve an additional purpose such as in the case of raised crossings and junctions.
- Consider the use of potential 'low level' risks including conflict between road users.
- Avoid the need to incorporate signs into the design – the speed reduction should be self-evident and rational

Figure SM1: *A raised junction table within a new housing development*



Driver focus should be on the environment in which they are in and be alert to the presence of other road users at all times. All new developments should seek to achieve the design speeds of 20mph in what should appear to be a natural way through the appropriate selection of geometry and arrangement of the road.

A key contributing factor in successfully maintaining a design speed is to ensure the road design incorporates sufficient speed reducing features (SRF) which will make it difficult for drivers to travel in excess of the design speed. Avoiding long straights in a road's design will go some way to addressing concerns about traffic being able to comfortably achieve high speeds between junctions. If a new residential street is to have a design speed of 20mph then the distance for which a carriageway may remain straight and untreated by speed reduction features is 70m. It is important that this is achieved without the use of infrastructure that appears to have been retrospectively fitted to the road.

Of absolute importance in the application of speed reducing measures is the aim that these measures should appear effortless. In fact, they should not "appear" at all and should simply form part of the highway alignment with no emphasis placed on the fact that they are intended as traffic calming.

More comprehensive advice on the types of traffic calming features which can be used as well as their designs can be found in Manual for Streets 1 & 2.



Figure SM2: *Speed cushions applied retrospectively to a residential development diminish the road's character and impact negatively upon the place status of the road.*



Figure SM3: *Raised crossing helps cyclists and pedestrians across the carriageway, slows traffic on approaches and draws attention to the crossing point*

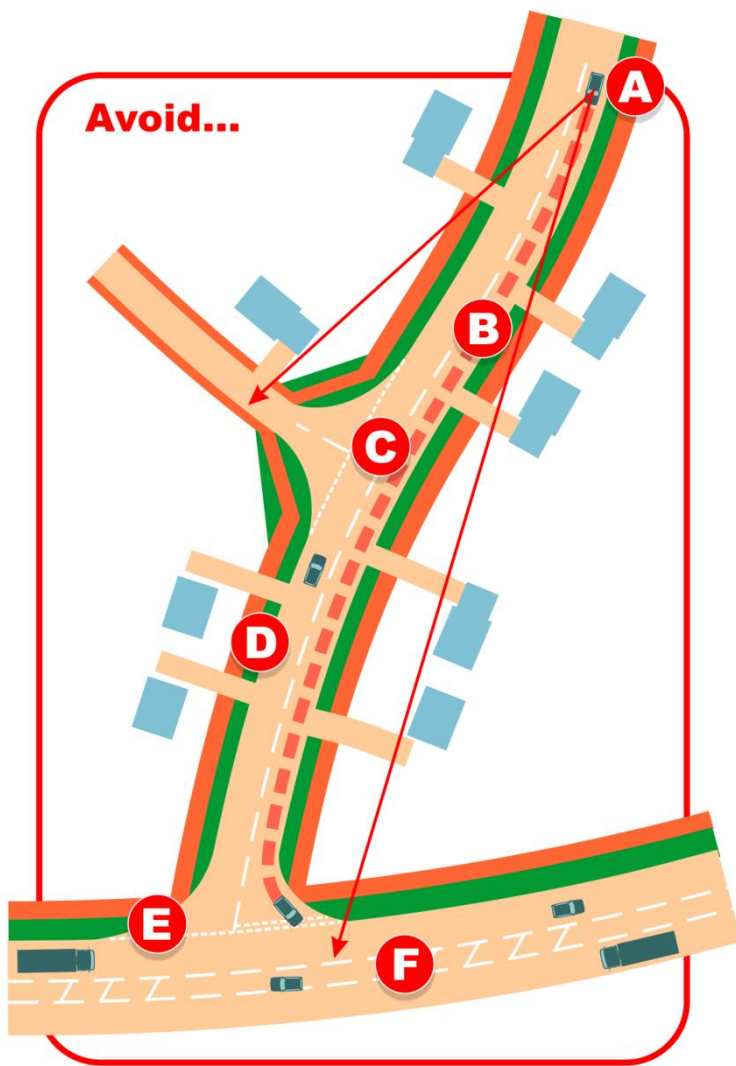

Figure SM4: Examples of bad design elements leading to speed issues

Figure SM4 shown above demonstrates some design options which may encourage faster traffic speeds within a residential development.

Used in isolation, these options should have only a minimal impact on speeds however if they are used in combination as shown in the illustration, the cumulative effect is likely to be much worse.

...A. Too much forward visibility

If this is too generous, it will allow the driver to feel overly confident as they can tell that they will not be coming into conflict with other vehicles over a long distance. This level of confidence means they could be encouraged to travel at greater speed.

...B. Long straights and only slight bends

If the carriageway generates very little horizontal deflection, vehicle speeds will remain relatively unaffected by the road environment and drivers will be able to maintain higher speeds. Curves which are to be used for the regulation of speed are generally recommended to turn at an angle of between 70 and 100 degrees to be most effective.

...C. Lane markings

The use of a central road marking gives motorists assurance that as long as they are in their own lane the risk of a head-on collision is low. This removes doubt and encourages traffic speed to creep up.

...D. Footway segregation

Verges between carriageway and footway will encourage speed as motorists are more confident that they have the width available to avoid pedestrian collisions.

...E. Wide sweeping corners

At junctions, an overly generous radius on the corners can encourage vehicles to enter and exit at speed. There is little physical requirement to hesitate if ample room is available to complete the turning manoeuvre.

...F. Excessively wide carriageway

If it is too wide for its intended purpose, a carriageway can allow vehicles to achieve inappropriate speeds. This is due to the perceived low risk of collision with oncoming traffic.

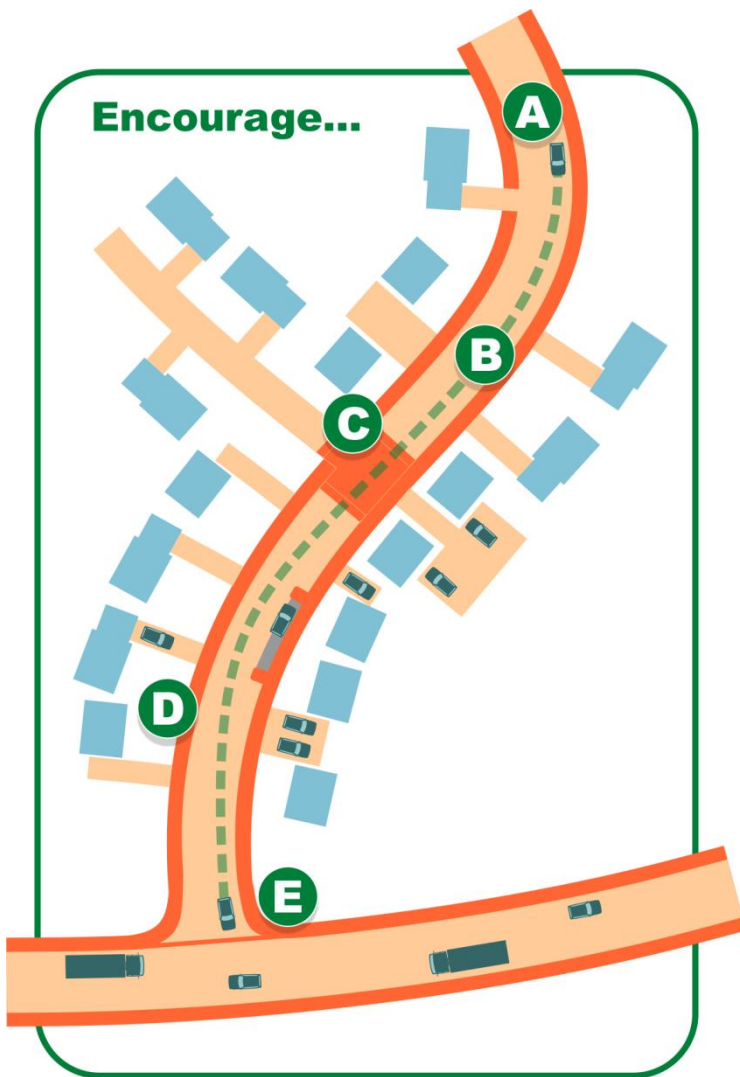

Figure SM5: Examples of good design elements for managing speed

Figure SM5 shown above demonstrates what can be achieved to manage vehicle speed in the design of the road layout.

...A. Restriction of forward visibility

Through a layout design that uses horizontal curves and the placement of buildings close to the carriageway, the clear distance that motorist can view the road ahead is restricted. Slower speeds will result as a consequence of motorists being less assured of their route.

...B. Carriageway alignment

This design has much more curvature in its layout meaning that there are shorter distances of carriageway between curves. There is less opportunity for vehicles to reach high speeds before they must turn.

...C. Deflections

Useful vertical or horizontal deflections will keep traffic speeds low as vehicles are deviated from their course. Combining the features with other design elements such as crossings or parking help them compliment the streetscene giving them an essential purpose and not just added for the sake of speed management.

...D. Footway proximity

It is important to keep pedestrians close to the carriageway within residential developments as it reminds drivers about their responsibility to vulnerable road users in that area. The lower the speed, then the safer that environment will be for shared use.

...E. Tight radii

Reducing the available curvature of the carriageway at junctions and accesses requires vehicles to engage with them at low speed. Other advantages are that pedestrians can cross closer to their desire line and are much more visible to turning vehicles.

Horizontal features

There are many ways in which a horizontal deflection may be incorporated into the road for the purpose of deflection. By removing the consistency of carriageway width drivers are forced into showing greater caution so that they do not come into conflict with other vehicles sharing the same road space. It is conceded that this approach is not suitable for every road in the hierarchy but where 85thile speeds are already below tolerances there shouldn't be any unacceptable risk associated with using carriageway narrowing to achieve slower speeds.

The following are all examples of horizontal measures which may be used for the purpose of speed management in residential environments.

- Build-outs
- On-street parking
- One-way systems
- Gateways

Figure SM6: *Raised crossing reduces traffic speed but can be compromised by parking issues*

Vertical features

Vertical traffic calming measures are the most visually intrusive in terms of their obvious purpose as speed reducing measures. In a new residential environment any such features are not considered acceptable for the purpose of slowing traffic. The reason behind this opinion is that vertical deflections portray an image of danger in an area where people should be able to feel safe. The features themselves are often unattractive and can come across as being unconnected to the street design and instead can appear to be retro fitted.

There will inevitably be situations however where all other traffic calming solutions have been considered but have been found to be unworkable and in such situations it may be necessary for vertical features to be used. In such circumstances there is a need for these vertical features to be designed so that they can be integrated into the road design in a sympathetic manner. One way of achieving this objective is to give the vertical feature a multi-purpose.

- Ramped pedestrian crossings
- Table junctions
- Raised entry points





Psychological

It is most beneficial to convince drivers that it is in their best interests to use the road space beneficial to residents, road users and society in general as an environment can be encouraged that seeks to develop respect amongst all those that move or dwell within it. There will always be exceptions to any such situation but it is much more desirable to have a road space which encourages low speeds through its character than a space which uses a collection of a regulatory measures intended to force obedience through the threat of prosecution or punitive damages.

Much of what has already been covered in this section use psychological measures within their design principles. Other options that use a psychological speed restraint approach include:

- Make no-go areas for traffic appear uninviting and uncomfortable, which could be achieved through the use of alternative surface materials than those used on the main vehicle carrying route. *E.g. through Squares*
- Minimum carriageway widths
- Interaction with pedestrians and constant reminders of their presence

This list is not exhaustive and Developers are encouraged to research and suggest their own methods.

The use of surface colouring, achieved through the application of 'Textureflex' or similar will not be considered suitable for adoption due to the long-term maintenance issues associated with these materials. If the material can be proved to be long lasting, then a case may be made for its adoptability.

Reducing visibility

MfS includes information based on research that demonstrates a link between reduced visibility and lower speeds. This could be accomplished through the placement of buildings within the development, which could be angled or moved in such a way that they create physical obstruction that the road must bend around. This kind of design approach demonstrates that there is purpose behind the layout and is very effective at convincing drivers to travel with care.

Visibility at junctions and forward visibility requirements are essential factors of road design and minimum requirements are provided on the grounds of safety. There can be exceptions to this rule however in some cases where a reduction in visibility can be used to force drivers to be more cautious. As long as risk can be compensated for in some way then there is a possibility that such a

design could be used. An example may be where there is a junction between a minor and major road but the driver of Vehicle A waiting at the junction does not satisfy the MfS or DMRB stipulated “y” distance along the right hand kerbline. In this instance it is important that Vehicle B, approaching that junction on the main road, is aware of the junction and can see that a vehicle is waiting there. Vehicle A will start to edge out into the main road and Vehicle B will be aware of the risk and slow accordingly.

This will of course also be the case where buildings are proposed for use as deflection measures to determine safety issues.



FigureSM7: Curvy estate road with sharp bend

*If reduced visibility is being considered as a preferred design approach and will require a variation away from the standard forward visibility requirements and splays at junctions then any proposal **must** be discussed early in the design process with the County Council.*

Chapter G. Gradients

Gradients are an essential aspect of road design with longitudinal gradients having a significant effect on vehicle speed and safety, particularly on larger, heavier vehicles. Gradients will dictate whether vehicles are able to cope with braking on a descent and also whether they can maintain safe traction on ascent.

Cumbria is home to some of the steepest adopted highway in the UK with gradients as steep as 30% on Hardknott Pass. Such extreme gradients are unsurprisingly not desirable in new developments where a maximum gradient which sits within the range of plus to minus 10% (1 in 10) is preferred. There may be a need to increase this maximum where the topography of a site will not allow for the use of a lesser gradient and in

such situations the highway authority may permit an exception to the percentage but this will only be achievable through early discussions with the County Council.

An upper threshold of 6% gradient is preferred for longitudinal carriageway in new developments although this should be set at 5% if pedestrians will be using the route. The County Council will seek reassurances that any increased gradient will not adversely affect the operation of the road including accesses and footways.

Figure G1 shows the visibility requirements at locations within the road where the gradient changes between negative and positive and vice versa. These two types of situations are referred to as either a 'crest' in the road or a 'sag'. The top of objects in the highway with a vertical height of 600mm should be visible to approaching traffic with sufficient distance so that the vehicle can come to a stop within the appropriate length of SSD.

Figure G1: Visibility requirements when confronted with crests & sags in the road

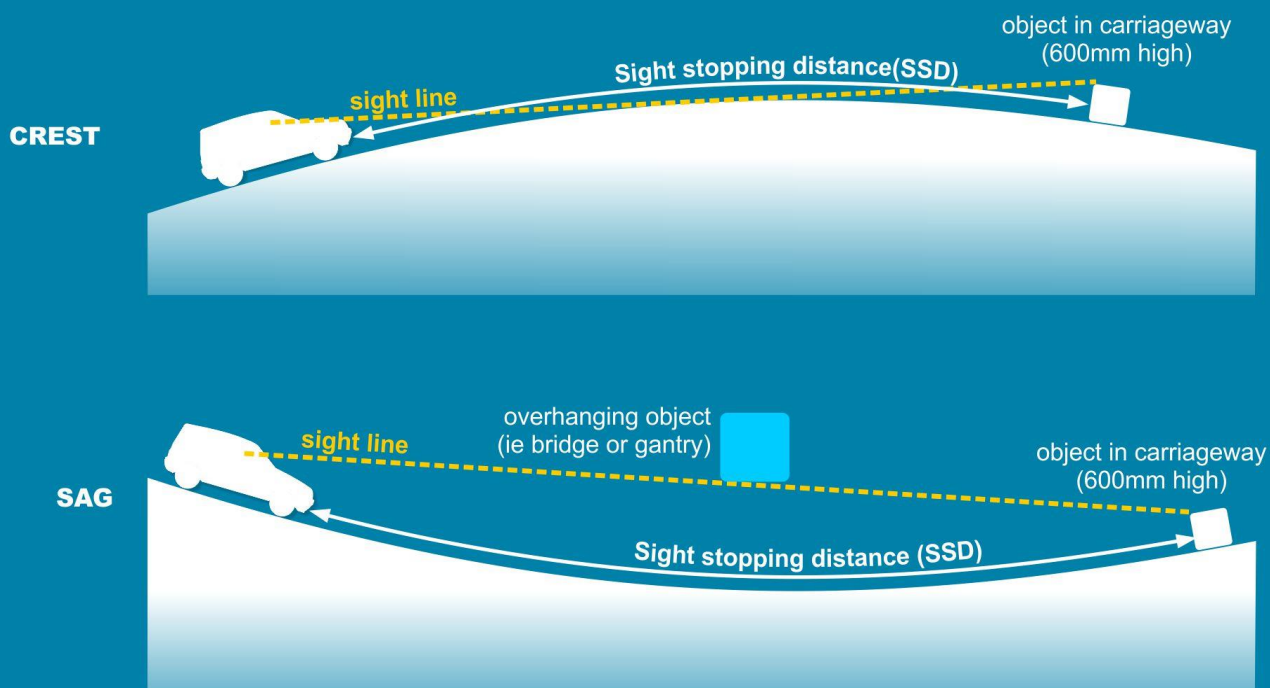

Dwell areas between roads

There should be an aim to provide a safe transition point between roads where at least one of those roads has a significant gradient. The 'dwell' area allows vehicles to wait at a junction or access point without risking stalling the vehicle or slipping.

Carriageway widths with significant gradients

The width of the carriageway will need to be a strong factor when designing a carriageway on a steep gradient. If for instance a cyclist is ascending the slope, they may be swerving more than they would do on a more level surface.

This lateral movement across the carriageway is referred to as their dynamic envelope. LTN 2/08 states that at speeds below 7mph, cyclists will require an additional 0.2m to their travel corridor and at even lower speed such as 3mph, 0.8m of additional width may be required.

This means that additional road space is required for vehicles which are overtaking. The gradient may even force a cyclist into dismounting and pushing the bicycle up the slope which would increase their effective width to over 1m and push vehicles even further over. This situation is demonstrated in Figures G2 and G3 where a comparison is shown between a shallow gradient and a steep gradient and the difference in carriageway width required by cyclists.

Choice of surface material

Material selection is an important consideration where gradient plays a part and it is generally recommended that the use of block paving materials be confined to gradients of up to a maximum of 8% only. The purpose in setting this maximum figure is that issues are likely to arise in excess of that gradient which may lead to a rapid degradation of the highway. Designs which feature block paving on carriageway gradients, exceeding +/- 8% will need to be agreed with the highway authority.

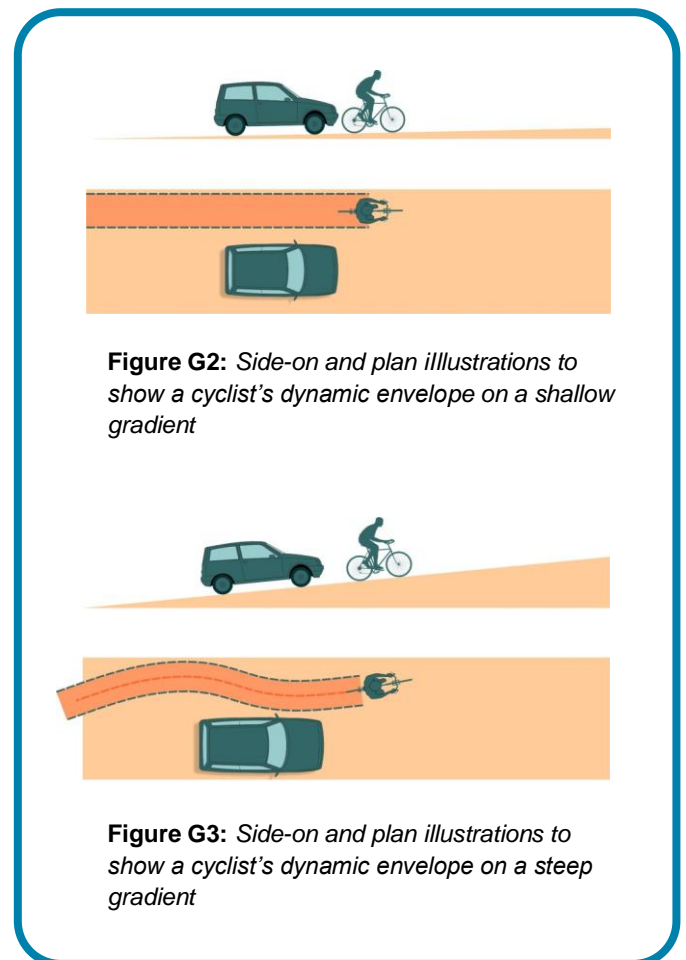

Figure G2: Side-on and plan illustrations to show a cyclist's dynamic envelope on a shallow gradient

Figure G3: Side-on and plan illustrations to show a cyclist's dynamic envelope on a steep gradient

Surface water

Gradients are essential components of road design as the failure to adequately deal with drainage issues can have a significant impact on road safety. Minimum gradients must therefore be designed into the surface to ensure that surface water can be directed away from the main travel corridors and allow unimpeded movement.

Crossfall provides the means by which surface water can be directed to drainage points in the road. A figure of 2.5% is usually sufficient to accommodate this function although a maximum value of 5% can be used as a limit. Any crossfall that exceeds this 5% will present an unacceptable risk to pedestrians, cyclists and motorcyclists in icy and wet conditions.

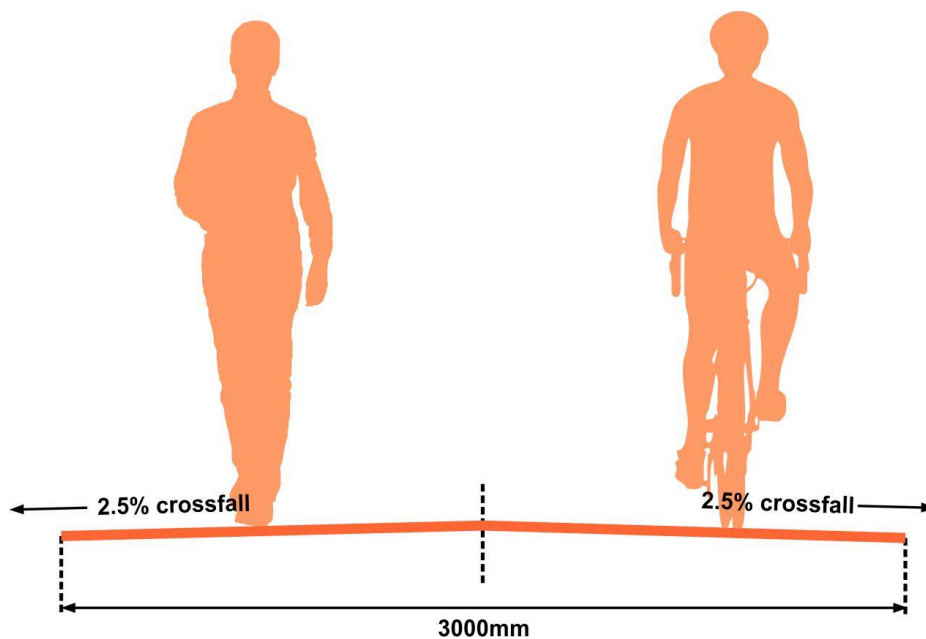

Figure G4: Crossfall from centre of shared path

Chapter H. Vertical clearance

Pedestrians and cyclists

Footways and cycle tracks will not need to meet the same standards as the motor vehicle carrying portion of the carriageway and as such the minimum heights required for pedestrians and cyclists are those suggested below.

Pedestrian	2.4m
Bike and rider	2.6m (2.4m min)

In special cases there may be a need to consider vertical clearances when riding a horse, in such situations a judgement will be made specific to that case. Guidance can be taken from *DMRB TA 90/05*

Vehicles

The vehicles which are intended to use the road will dictate the selection of an appropriate vertical clearance height for that road. Public roads must have a minimum of **5.3m** unobstructed height clearance without the need for signing and a minimum of **5.7m** is required below footbridges.

These minimum clearances could be reduced further depending on the type of road. In instances where height restrictive structures have been designed as part of gateways or entrances to mews or courtyard spaces an absolute minimum clearance height should be able to accommodate access for a refuse vehicle which will require **4.5m** of clearance.

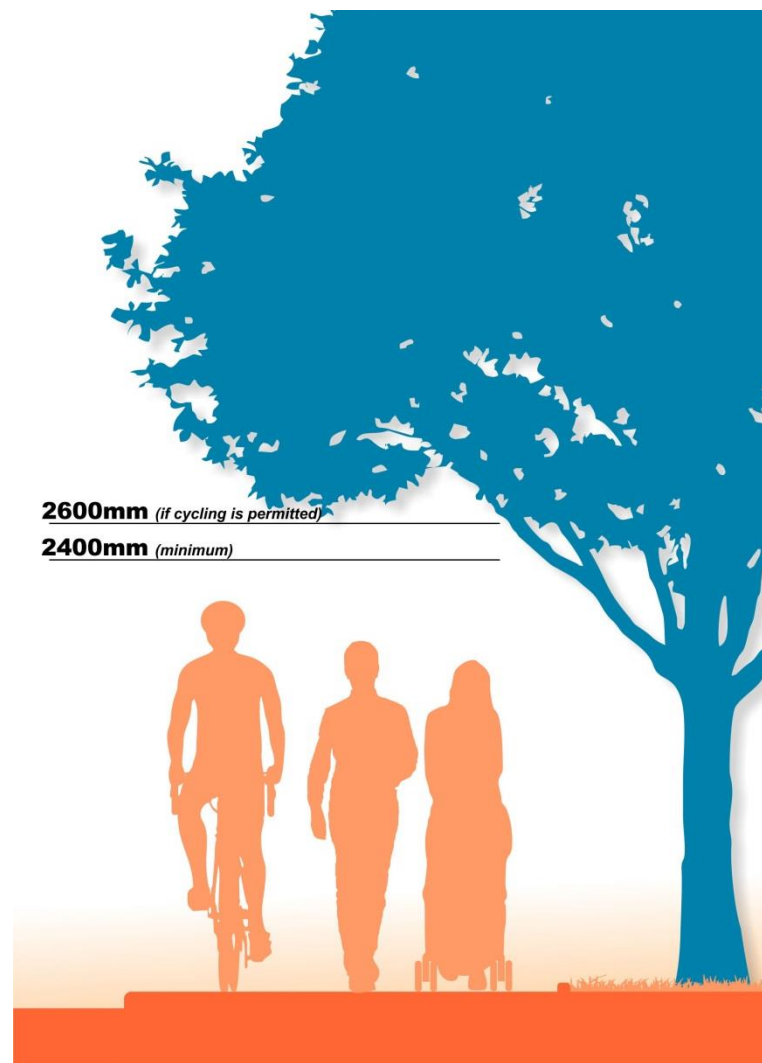

Figure VC1: Pedestrian and cyclists clearance requirements

Chapter I. Signs & markings

The presumption is that new residential developments will not require the use of signs or road markings within their layouts. Developers should seek to make this the case through appropriate design choices. Where possible the behaviour of road users should be encouraged by design features and layout rather than resort to signage or markings - both of which require maintenance and can result in a visually cluttered streetscape.

Signs

Within a residential development there should be the assumption that no traffic signs will be needed. Any issues which would normally require traffic signing should have been addressed through the design process meaning they will not be needed.

Exceptions to this assumption will be at entry points to the new development if there is a change in the posted speed limit and roundels are required. Any TROs associated with parking in the new development also need to be considered carefully to avoid intrusive signs appearing. Options such as designating the development as a controlled parking zone may be a solution as this uses signing only at the entry points to the zone.

If all other options have been assessed and the result is that signs are still required, it is imperative that their visual impact on the environment be kept to a minimum.

Intrusiveness of signs can be lessened through appropriate design consideration to include factors such as the sign's size, mounting height, lateral position to the carriageway and selection of mounting surface.

Figure SM1 is a common sight near the entrance to developments and is a required sign warning of road humps. Lighting is no

longer required for this sign and its impact can be reduced if it were to be grouped with the other necessary pieces of street furniture behind it.

Figure SM2 demonstrates a situation that should be avoidable within new residential developments. The sign warns of a playground at this location but as traffic speeds should be below 20mph and drivers need to expect this kind of activity anyway there is very little advantage gained by the provision of this sign.



Figure SM1: TRO sign at entrance to housing estate



Figure SM2: Warning sign on a residential street – is it necessary?

Markings

As with traffic signs the need for road markings within a residential development should ideally have been negated through the design process. Road markings in residential areas can unfortunately impress on people the image that motorised traffic is the most important mode in that space which goes against the hierarchy principle set out in the Introduction section of this guide.

The absence of markings creates an environment in which the barriers between road users is blurred, particularly on shared surfaces, and this serves as an indication to all that the road space in that area is not defined for individual users.

Parking bays marked out in paint will generally not be accepted within residential developments. Alternative methods for demarking bays should be used such as contrasting materials for the bay itself and/or setts to outline the bay area. The DfT's policy paper 'Signing the Way' includes new advice on making provision for parking areas.

Where all alternatives have been considered but it remains the case that markings are necessary to enforce a Traffic Regulation Order (TRO), consideration should be paid to the width of lines being used and their colour tone. Cumbria County Council does permit the use of some alternatives depending on the character of the area in which they are being applied.



Figure SM4 (above): Presence of white lining detracts from the residential character of the streetscene

Figure SM3 (below): Flush kerb used as an alternative to a painted give-way marking

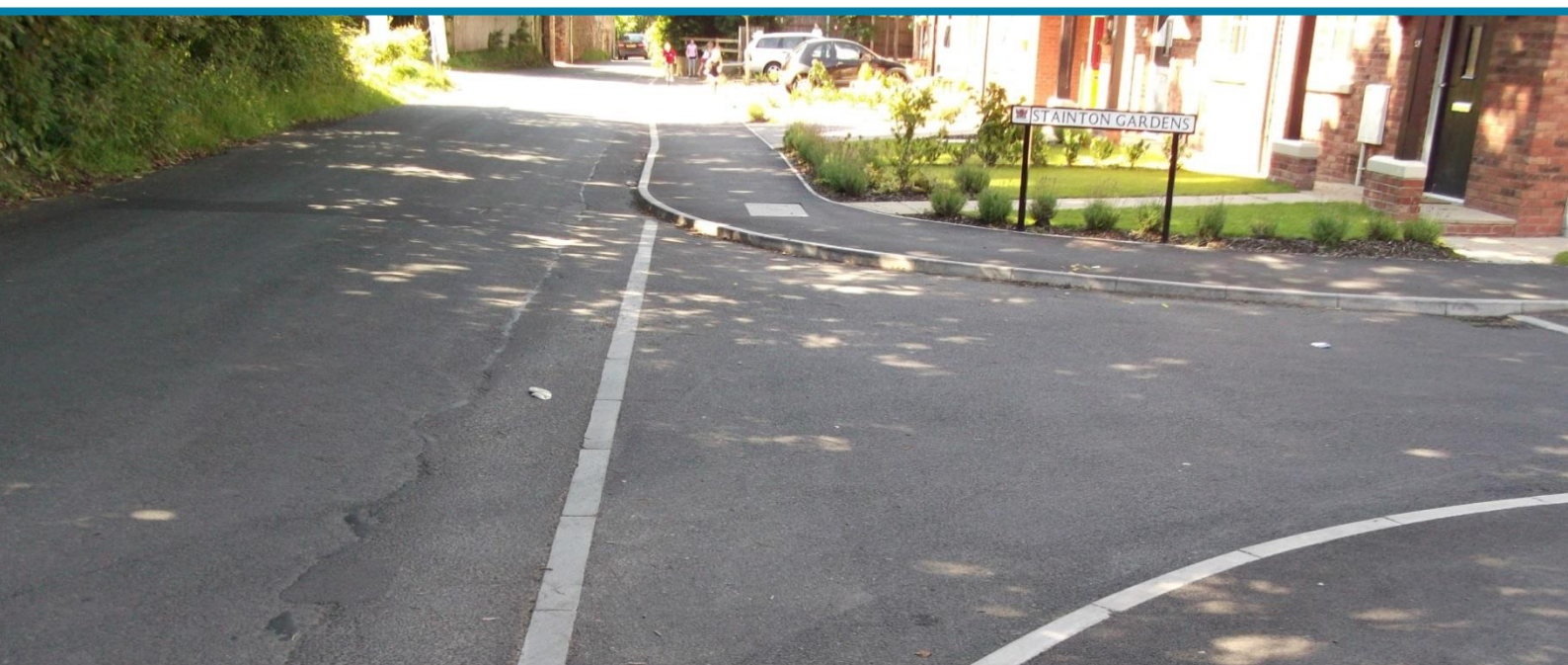

Chapter J. Parking

This guidance replaces the *Parking Guidelines in Cumbria (1997)*

Parking is essential to the success or otherwise of a residential development. If managed correctly, the environment will be one where stationary vehicles can be accommodated whilst still allowing for other road users to carry on with their business unhindered or at least only minor inconvenience. The problems that occur if parking is not sufficiently designed for can soon escalate into major issues that compromise not only the efficiency of the highway network but the safety and living standards of residents.

The main issues that arise from residential parking include:

Obstructions to pedestrian movement

This occurs where vehicles are parked partially or wholly upon the footway. The result is that pedestrians are forced into entering the live carriageway, a situation which is not always easily achievable for those with mobility impairments or visual impairment.

Barrier to free movement of emergency vehicles in the course of their duties

Pinch-points created by badly parked vehicles could prevent fire appliances from accessing an emergency situation. Due consideration needs to be given by the developer as to how access can be maintained.

Obstructions to private driveways and property

Annoyance can be generated in residents where inappropriately parked vehicles block access arrangements to dwellings.

Congestion on bus and refuse vehicle routes

If parking takes place at potential choke points within the development there may occur instances where routes become impassable by large vehicles. Buses and refuse vehicles can find their paths blocked which forces them into manoeuvres that present risk to the vehicle and others within the road.

Damage is inflicted on footways and verges

Footways and kerbs that have not been selected with vehicle mounting movements in mind will deteriorate quicker than the intended design life of the surface. These surfaces must be constructed to the appropriate standard or the design must prevent parking in such areas. Grass verges are often left open to abuse from parking as they are seen by many as excess surfacing, useless and good for nothing else other than parking. The over-run of these verges damages the turf and results in unattractive, maintenance intensive, unsafe part of the highway.

The character of the development is tarnished by excessive parking

The extent to which vehicles are parked in a residential area will have a significant input into how people are able to navigate the space. When vehicles are parked between buildings and the carriageway the impression is one of the car being the main priority in that space. This is something that the guidance strongly wishes to challenge as pedestrians must be the priority in new developments. Pressures on the amount of parking space available may encourage some homeowners to create additional parking within their curtilage by converting landscaped areas in hardstanding (and sometimes not even that).

Parking should be designed so it does not detract from visual amenities of the area. The use of different type of surfaces e.g. 'Grasscrete' and landscaping should be considered.

Parking numbers

Planning applications are determined in accordance with the Development Plan (the Local Planning Authority's adopted policies) unless material considerations indicate otherwise. Material considerations can include national planning policy as set out in the National Planning Policy Framework, Government policy as set out in ministerial statements, or site-specific circumstances.

Guidance on parking numbers can be found in Appendix 1

The guidance is provided to support Local Planning Authorities in assessing the potential impacts of development on a site-by-site basis within the context of the Development Plan, site specific considerations, and other material considerations (such as national policy). Developments may prove acceptable without offering parking levels as indicated below, or prove unacceptable despite offering parking levels equal to or greater than those indicated, depending on the circumstances.

Importance of 'Good' design

The unfortunate truth is that space will always be at a premium in the highway and people will tend to use the space that they consider suitable for their needs. There is no doubt that the issues which have been listed in this section will continue to persist within future developments but this does not mean that nothing can be done to minimise the effects.

A good design should be able to identify where problems are likely to be encountered within the layout and provide mitigation measures to lessen their impact. Developers should provide evidence as to the thinking that has gone into designing for parking and how the issues mentioned previously would be addressed.

A well planned system of parking within a residential development can act as a very effective device for managing traffic speeds. Parking, if well designed for, can become an extremely useful asset in terms of safety and comfort with a development. The success of parking arrangements within schemes will only be achieved if developers devote enough consideration to these issues.

Resident parking

If parking is provided within the curtilage of the property such as a driveway the space needs to be long enough to accommodate a vehicle without protruding out from the property into the footway or other part of the highway. It should also be possible for any doors or gates to be operational whilst the vehicle is on the driveway, which means that a garage (where provided) or door must be accessible as should any opening gateway at the commencement of the driveway, doors or gates should also not open into the highway.

The width of driveway will depend on whether access is required to both sides of the vehicle and whether the driveway also incorporates the 'by foot' access to the dwelling. A minimum width of 3.2m is recommended to allow for this access.

The driveway should ideally have a gradient of less than 10% (1 in 10) for the first 6m behind the highway edge. Figure P1 shows these extremities along with the preferred range of gradient. This preferred range is between a 10% incline away from the carriageway to a 10% decline away from the carriageway. The maximum permissible gradient is 12.5% (1 in 8).

Patterns of vehicle ownership throughout the county mean that a one size fits all approach will not always work when it comes to the provision of parking measures within residential developments.

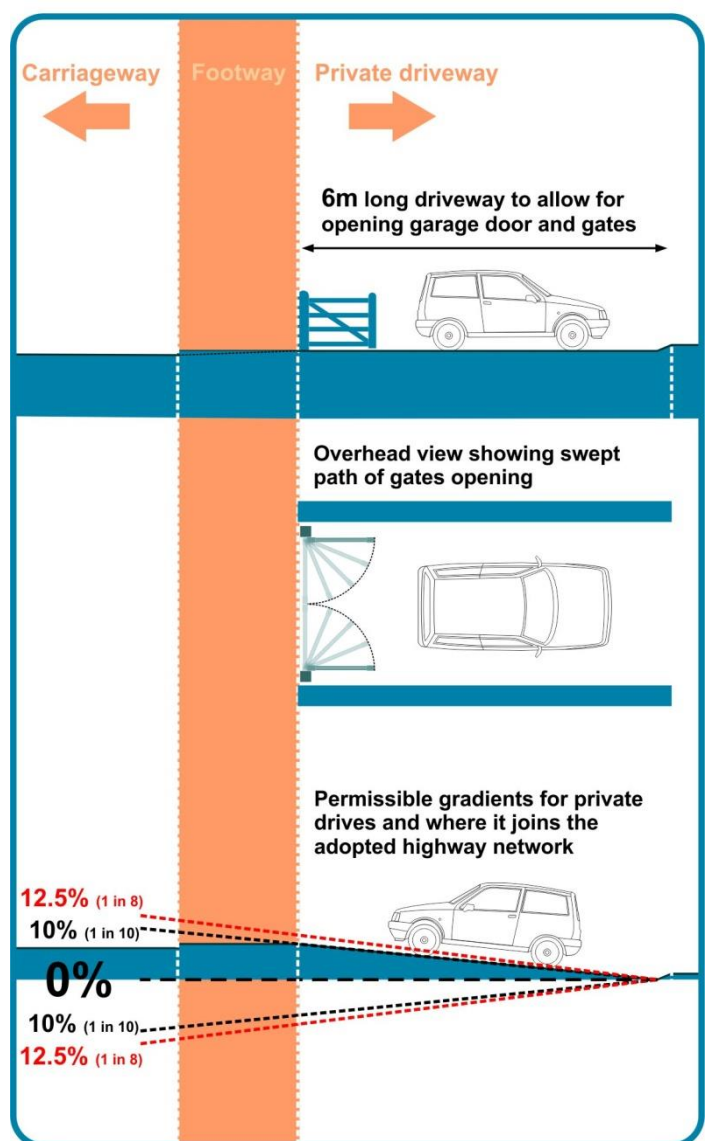

Figure P1: Private driveways

Visitor parking



Figure P3: *Retrospectively installed makeshift bollards*

In this shared surface street (Figure P3), stones have been laid on the property boundary in what would appear to be an attempt to prevent overrun or vehicles parking on that section. This demonstrates the importance of providing adequate parking places for residents and visitors. The curve of the road at this point has created this area and so the design should consider whether additional measures should have been introduced such as thick vegetation, bollards or some alternative surface treatment which would deter parking.

Grass verges that separate footways from the carriageway are not recommended in new residential developments. They are at a high risk of damage by vehicles that park over them, which will lead to maintenance issues.

In Figure P4 you can see that vehicles are parking half-on and half-off the available footway. The carriageway is at the same level as the footway which may have had an influence on this. Drivers have chosen to adopt this method of parking their vehicles in this streetscape and means that pedestrians are forced into the carriageway.

Does it matter? An argument in this situation would be that vehicle speeds are low due to the block paved surface and lack of verges and therefore there is no significant risk created for pedestrians through the blocking of the footway. Although the consequences are

not considered to be highly negative with this example, where it does introduce a problem then retrospective steps would be required to provide a solution. A TRO to restrict parking may be required along with the signing and road markings that it would necessitate. A physical restriction may be needed and require the installation of bollards on the footway edge. The need for any of these retrospectively applied actions would show the design stage did not fully anticipate abuses of the development layout and confirms the importance of intelligent design at the outset.

In areas of shared space, designs need to take into account the likelihood of inappropriate parking occurring. Keeping vehicles away from tactile paving strips or other aids, which are intended to assist those with visual impairments, is imperative as these features should not be compromised.

Parking can be used to benefit the way that a road operates as it can be an effective tool in managing traffic speed. The presence of stationary vehicles on-street effectively narrows the carriageway and reduces forward visibility. Physical demarcation of parking areas through the use of physical stoppers at either end of the parking can act as an effective build-out and has the added benefit of remaining effective even when vehicles are not parked within its constraints.



Figure P4: *Parking on the footway*

Parking bays

The diagrams on page 59 show the minimum widths required for a parking bay dependent upon the angle of that bay to the main carriageway. The width of carriageway allows for vehicles to manoeuvre in and out of the spaces without collision.

Parking bays where they are provided should not be marked out in paint or thermoplastic surfacing. These materials detract heavily from the character of a residential area where they fail to add quality or character to the streetscape.

The preferred alternative for demarking bays is to use a contrasting colour or texture of material. An example of this would be through the use of blocks of stone set into the carriageway to replicate a dashed line effect.



Figure P5: *Parking bays marked out in quality materials*

The development in Figure P6 has used flush fitted units to delineate parking spaces on the right hand of the image, however, painted road markings have been used for the spaces on the left. This treatment is not suited to such a small area as it comes across as a retro-fitted solution.



Figure P6: *Parking bays in a new development*

Echelon bay alignments

MfS recommends that parking in echelon bays should use a reverse-in drive-out arrangement where vehicles drive past the bay and then reverse into it. The developer is encouraged to look at the pros and cons of using either a reverse-in or forward-in movement and to base their judgement on what represents the most appropriate solution in that particular situation. The decision about which alignment to use will depend on a number of location specific factors such as visibility, the type of road, presence of footways, etc.

Carriageway widths that are deemed appropriate within different types of road is provided elsewhere in this guidance. If the angle of echelon parking dictates a wider carriageway width than would normally be prescribed on a particular road then this will be acceptable but generally only for the extent of the parking bays. Figure P7 shows the standard widths needed in relation to the angle of the bay.

Dimensions

The standard dimensions for a parking bay is normally 2.4m by 4.8m. However in most cases this should be increased to 2.6m by 5m to allow for earlier turn-in by vehicles using a narrower carriageway width than the ones shown in Figure P7 as well as easier access for less ambulant people or parents of small children. If a 2.4m by 4.8m bay is chosen by the developer, then they must prove the

validity of the design through production of a swept path analysis and user matrix.

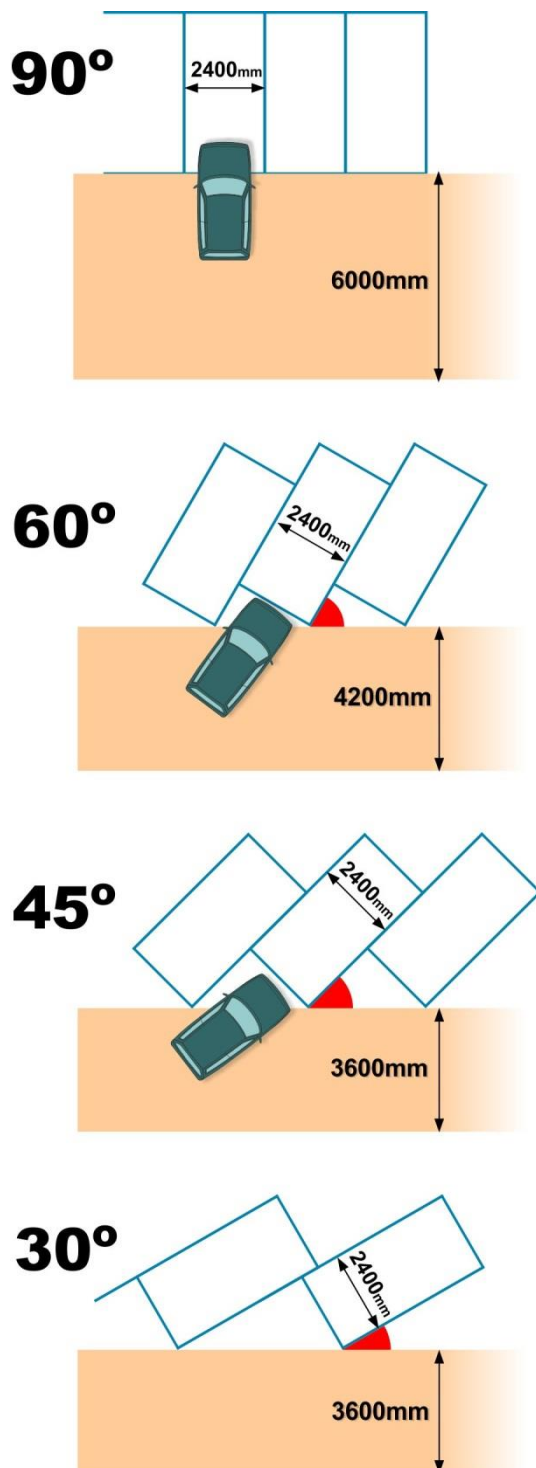

Figure P7: Parking bay layout options and their required carriageway widths

Courtyard parking

Parking areas that are provided away from the road network can free up the on-street spaces for visitor parking. This arrangement helps to effectively increase capacity and alleviate some of the issues that have been covered previously in this section. There can be some resistance by residents to use these courts however if sufficient thought and care has not been paid to their design.

The use of courtyard parking facilities must include an assessment of security and safety for those using the facility. How well the area is overlooked in terms of its exposure to natural surveillance will have a significant effect on how confident people feel when using it. It is therefore vital that the risks of anti-social behaviour and crime are well considered and addressed by the developer.

Parking courtyards which are located behind buildings and are hidden from the main carriageway are often not trusted as safe or convenient areas by residents. This can lead to courtyards being left vacant or under capacity as people decide to park on-street instead. Nevertheless, it is preferable to draw some parking away from the street. The layout of parking courts is the responsibility of the developer and they are encouraged to explore designs which would appeal to residents to use the facility rather than occupying on-street space.

Traffic Regulation Orders and parking enforcement

The requirement for a Traffic Regulation Order (TRO) to enforce parking arrangements within a residential development is only to be considered as a last resort measure. The application of road markings in these developments as well as the use of traffic signs does not support the principles of this guide and those promoted through Manual for Streets 1&2.

It is accepted that the introduction of a TRO can be legitimate when all other alternatives to

prevent parking have been ruled out. This should not be the case with new developments however as this is the best opportunity that exists from the outset to get the design right and negate the need for a TRO.

Where TROs are required in residential developments, the minimum of associated infrastructure should be used. Signs should be kept to the minimum permissible dimensions and located considerately in line with guidance provided through MfS 1&2. Markings on the carriageway should only be used to enforce the TRO and minimum line widths as well as subdued colour tones should be used so as not to impact on the character of the area too negatively.

Generally, TROs are viewed as being more of a retrospectively applied measure that seeks to address a pre-existing problem. This should not be the case with new developments as good designs should address the issues.

Cycle parking

Formal cycle parking within residential developments will be most probably confined to communal buildings with a number of tenants possibly distributed over a number of floors.

Cycles require physical infrastructure so that they can be securely parked. Consequently, any infrastructure which is selected should be done so whilst considering how to minimise the need for street clutter. For example, can the stand serve a dual or multiple functions?

Developers should ensure that adequate cycle storage facilities are included within the curtilage of each dwelling.

Principles for cycle parking provision:

- Sited in locations that allow good access to the development facilities. Proximity of the cycle parking should predominantly take precedence over motorised vehicle parking allocation. This demonstrates support and encouragement for cycle usage.
- Access to the cycling facilities needs to be simple and non-obstructed. Ideally, cycling should be possible all the way to and from the parking area without the need to alight.
- Security needs to be well planned for the provision of cycle parking both in terms of protection to the riders and also for their cycles when left unattended. Locations need to be selected that offer a good level of natural surveillance from passing traffic and surrounding buildings.
- Shelter should be considered wherever possible.
- Where possible, provision for cycle storage should be made within the curtilage of the dwelling.

Chapter K. Utility services

The main recommendation when planning the integration of utilities into a new development is to ensure that early engagement between the developer and utility companies takes place as part of the design process.

Maintenance issues

The width of the road must be able to accommodate any future streetworks that are required to access utility services. This will need to take into account the excavation itself plus any safety zones required during the works

Surface materials will need to be selected with the location of utilities in mind. Designers should account for the future maintenance requirements connected with utilities provision and provide information on how excavations should proceed and plans for reinstating the road surface materials. This additional planning should not serve as an excuse to choose hot rolled asphalt for use everywhere as this minimal material choice will give the development a low quality appearance.

If a permeable layout is used by the development then any issues when it comes to excavating will be minimised as access will be maintained during works.

Planting

Where pre-existing planting such as trees are to be incorporated into the new development it is essential that these features are identified so that an assessment can be made as to how they will cohabitate with new services. This same consideration must be given when designing in new areas of planting, ensuring that sufficient barriers are implemented between root systems and service ducts.

Depths and lateral positions

The standard details of where services should be positioned in order to minimise danger to anyone excavating as well as to the equipment itself are described in the National joint Utilities Group (NJUG) publication on the positioning and colour coding of underground utilities' apparatus. Figure U1 below shows how the various utilities are to be distributed beneath a generic 2m wide footway.

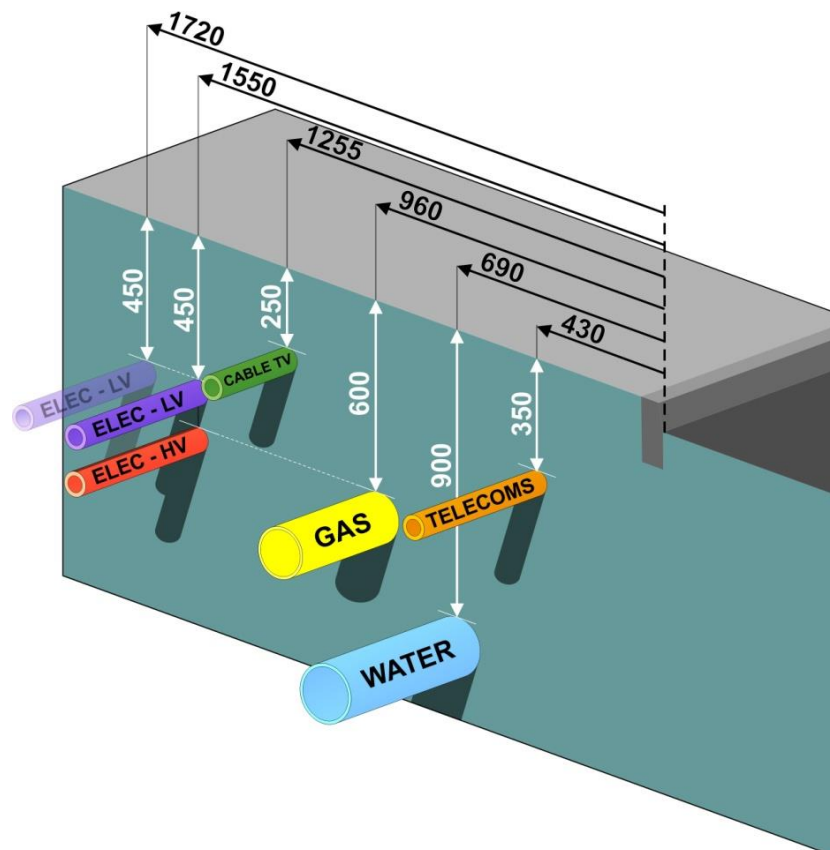

Figure U1: *Lateral positions for services in the highway*

Lighting columns would also be expected to be installed at the back of the footway as far from the kerb face edge or carriageway as can be achieved whilst also satisfying the design criteria for that lighting system.

When designing for sub surface utilities attention should be paid to the alignment of service covers in that surface. Too often are there examples which emerge within new schemes that have failed to integrate covers into the streetscape and resulting in something that looks awkward in its surroundings.

This issue is represented in Figure U2 which shows how the alignment of setts within a shared surface area is not mirrored in the placement of the service access cover.



Figure U2: *Awkwardly aligned access cover is made apparent through use of setts*

By installing the cover in the manner shown in Figure U2 it has made the task of integrating it into the surface more complicated as surrounding setts/pavers have had to be angled to accommodate it. It would have been simpler, both to install and to maintain, if the cover were in alignment with the surroundings.

Chapter L. Lighting

Cumbria County Council's Road Lighting Policy 2014 sets out minimum standards required for highway use

The provision of road lighting in residential developments which is intended for adoption by the local highway authority is the responsibility of the Developer.

The standard to which road lighting is to be designed is contained within BS EN 13201 and BS5489.

It should be recognised that Cumbria is a diverse county and that new lighting installations are sympathetic to the environment in which they are located. This shall be achieved through careful selection of the appropriate lighting standard and lighting materials.

Lighting materials are often selected in accordance with the way they will contribute to the streetscape aesthetic which can compromise performance criteria such as energy efficiency and illumination levels. The materials selected must satisfy the standard which is necessary for adoption if that is to be the desired outcome. Hazards such as severe bends or speed management measures will most likely warrant the presence of lighting. Detailed guidance can be found in Appendix 10.

Locating the lighting

The appropriate placement of lighting furniture needs to take into account how highway users will interact with it or preferably **not** have to interact with it at all.

Ideally, lighting columns will be installed at the back of the footway, but within the highway boundary or highway boundary, in the case of shared surface streets.



Figure L1: LED lantern used within residential development in Cumbria

This arrangement will leave the footway clear for use by pedestrian movement and poses a lower risk to those with a visual impairment.

Figure L2 demonstrates the risk that is introduced when lighting and other road furniture is positioned inappropriately. This is 'square' highway design with no delineation to clearly separate pedestrians from motor vehicles within the space. In order to navigate the space, those with a visual impairment are likely to follow the outer edge of the square but this would place them in direct conflict with the lighting column. The colour tone of the surface in comparison to the finish on the lighting column does not have sufficient contrast meaning that the column is a collision risk for vehicles as well as pedestrians.



Figure L2: *The position of the lighting column within a square puts it at risk of collision with vehicles and pedestrians*



Figure L3: *Shared Surface Street with lighting column set back from carriageway edge*

Figure L3 shows a good treatment for keeping lighting infrastructure away from the carriageway edge in a shared surface street. An area of hardstanding has been provided in front of the column to safeguard future maintenance.

An easement with the property owner is required in order to mount a luminaire to a building. New residential developments should instead seek ways in which the footway and carriageway can be left clutter free without the

need to resort to mounting units on buildings. Although this approach does offers opportunities for keeping the footway clutter free it is unlikely that the design would be acceptable apart from in exceptional circumstances and is more appropriate to existing built public realm than those that are to be newly developed.

Safety

The main purpose for the provision of lighting in residential developments is to make the space safe to use. Due to the likelihood of pedestrians and vulnerable road users being present in the environment, an adequate level of illumination will be required to make these road users visible to one another.

A night time road safety audit will be required as part of a Stage 3 audit and this will assess whether lighting levels are sufficient for the development and are not creating any highway issues when in operation.

Chapter M.

Landscaping

Landscaping within both private and public areas has long been an important aspect of creating attractive areas which enhance quality of life. The use of landscaping in developments is vital in cultivating an identity for new development and in assisting its integration into the existing rural or urban environment. Landscaping principles for new schemes should be based on a review of the site's wider context, to help determine an appropriate design'..

The use of landscaping, although highly recommended, must also be appropriate for its environment. Consideration must be paid to the purpose of the planting and how it can best located and maintained.

Cumbria County Council, in conjunction with the six district authorities within Cumbria has produced

Cumbria Landscape Character Guidance and Toolkit: Parts 1 & 2

The document includes advice on how to record the important influential factors of a particular area and can help to shape decisions regarding specific elements of a development's design.

<http://www.cumbria.gov.uk/planning-environment/countryside/countryside-landscape/land/LandCharacter.asp>

Retention of existing landscape features

If there are landscape features present on pre-development land and those features are worthy of retention then the resultant design of the highway layout needs to take this into account. The position of an established tree for instance may dictate where accesses or junctions are placed so that visibility splays are not compromised. Likewise, where bushes, hedges and shrubs can be retained and incorporated into a design such that they can perform a beneficial task such as creating barriers then they would be preferred over any simulated engineered measure.

Figure L1 is an example of how housing has been distributed around an existing tree which provides a landmark for the location and important character.



Figure L1: *Established tree used to influence the layout of surrounding houses*

The Highway Authority will not take on the maintenance responsibility for established landscaping that lies outside of the existing highway boundary.

Carriageway proximity

The creep of vegetation growth from the verge into the carriageway or footway must be managed in order to retain the original aims of the highway design including all the elements of road safety, design speed, adherence and user activity. Care must be taken to design out any conflict that may occur between root systems and utilities buried in verges and footways.

Figure L2 demonstrates how thick planting next to the carriageway edge prevents parking in that space and helps to give the impression of a narrow running lane which is better for keeping traffic speeds calmed.



Figure L2: *Shared surface street with adjacent planting*

Considerations that need to be taken into account before planting is introduced into the streetscape will include:

- Any trees which are to be located within the adoptable highway area need to have a canopy height which allows good visibility for drivers and other road users on approach.
- Large canopies on trees will cast shadows which may create areas of poor visibility disguising road users from one another. Damp may prevail in shaded areas also adding to the risk of spots of ice occurring or areas of reduced surface friction due to mossy growth.
- The selected species should be chosen with consideration given to how long its foliage will be on display seasonally, the colours that will be displayed and the amount of foliage that will be discharged come autumn.
- Any trees which produce particular types of fruit or flowers, may consequently attract wildlife that can lead to the carriageway below becoming covered in animal waste. An accumulation of this waste is not only unsightly but also potentially unhealthy for anyone coming into contact with it.
- Trees can be planted within a range of infiltration SuDs components to improve performance or as a standalone filter for pollutants from runoff directly. Trees in planting beds, pits, structural soils below pavement can be used as part of the surface water management system.
- Road lighting must be unaffected by the location of trees with care taken to ensure shadows are not created in the hours of darkness.

Gateways

The use of short sections of hedgerow or thick planting can also be incorporated into gateway features for instance as shown in Figure L3. The effect is to maximise the change in character between the major road and the residential streets, slowing traffic as it turns in and also keeping emerging traffic to a crawl with limited visibility.



Figure L3: *Landscaping used at Gateway to residential development*

Designs should of course seek to anticipate problems that could arise as a result of the development layout. It may become the case that in the situation shown in Figure L3 pedestrian traffic may start to use a desire line which takes them on a direct route across the grass verge to cross the junction mouth. This may be considered to be a rare event or one which only a minority of pedestrians will likely do, therefore as long as this has been considered the design should be acceptable.

Adoptability of landscaping features by the Highway Authority

Generally, the Highway Authority will only be prepared to adopt hard standing areas such as paved carriageways and verges which serve a highway junction.

Designs should not include short or narrow sections of highway verge that will prove problematic to maintain by the local Highway Authority. The Highway Authority will not accept designs that use verge areas to separate the footway from the carriageway.

A commuted sum will be sought from the developer to pay for the care of any trees located within the adopted highway.



Figure L4: *Short landscaped verge causes maintenance issues*

Species selection

A comprehensive list of species which could be considered for planting in the highway corridor is available in the County Council's Service Procedure [02/001: Issue of consent to District and Parish Councils – Tree and Shrub planting within the Highway](#)

Chapter N. Sustainable Drainage Systems (SuDS)

Local planning policies and decisions on planning applications in relation to major development (developments of 10 dwellings or more or equivalent non-residential or mixed development as defined in section 2 of the Town and Country Planning (Development Management Procedure) (England) Order 2015 must ensure that Sustainable Drainage Systems (SuDS) for the management of surface water runoff are put in place unless demonstrated to be inappropriate.

Planning applications for major development should therefore be accompanied by a site-specific drainage strategy that demonstrates that the drainage scheme proposed is compliant with the National Planning Policy Framework, National Planning Practice Guidance, and the Non statutory technical standards for Sustainable Drainage.

Standards required:-

- Flood Risk outside the development.
- Peak Flow Control
- Volume Control
- Flood Risk within development
- Treatment
- Structural integrity
- Design for maintenance considerations
- Construction

Non major developments (<10 properties) will be dealt with appropriately in line with above depending on local risk of flooding.

Developments should restore and enhance watercourses to reduce flood risk and to conserve habitats and species that depend directly on water, for instance, existing culverts within the site should be day lighted where possible.

Flood Defence Consent/Environmental Permit may be required for works in watercourses (including temporary works). Please contact either the Environment Agency or the Lead Local flood Authority for further for advice.

Figure S1: An example of a swale in a development



Drainage Strategy

Drainage should be considered early in the development planning and design process, along with other key considerations. Existing watercourses, existing flows of surface water across the site, and existing drainage systems, must be taken into consideration and the drainage strategy should mimic natural drainage patterns as closely as possible.

Water generated from off site that passes through the site must be managed so that it can continue to pass through the site without increasing flood risk.

Within the site, the most vulnerable elements of the proposed development should be located in the areas of lowest flood risk. This would usually mean that areas known to be at risk of surface water flooding should be left as green space within the development.

Priority must be given to the use of sustainable drainage systems (SuDS).

Sustainable Drainage Systems (SuDS)

Sustainable Drainage Systems (SuDS) mimic natural drainage patterns and provide water quantity (flooding), water quality (pollution), amenity and biodiversity benefits. The SuDS manual C753 (published by CIRIA) provides guidance on the planning, design, construction and maintenance of SuDS; available at www.susdrain.org/resources/ciria-guidance.html.

Other useful information:

- Rainfall Runoff Management for Developments <https://www.gov.uk/government/publications/rainfall-runoff-management-for-developments>
- Susdrain the community for sustainable drainage www.susdrain.org.

- UK SuDS Tools Web site - HR Wallingford www.uksuds.com.
- BS8582:2013 Code of Practice for Surface Water Management for Development Sites.
- Building Regulations 2010 Section H3 rainwater Drainage 2015 edition http://www.planningportal.gov.uk/uploads/br/BR_PDF_AD_H_2015.pdf
- DEFRA Non-Statutory Technical Standards for Sustainable Drainage Systems https://www.gov.uk/government/uploads/system/uploads/attachment_data/file/415773/sustainable-drainage-technical-standards.pdf
- DEFRA Non-Statutory Technical Standards for Sustainable Drainage Systems guidance notes <http://www.cumbria.gov.uk/elibrary/Content/Internet/544/3887/5894/4250810222.pdf>

The Management Train

A concept fundamental to implementing a successful SuDS scheme is the management train. This is a sequence of SuDS components that serve to reduce runoff rates and volumes and reduce pollution. The hierarchy of techniques to be used is:

Prevention

- Prevention of runoff by good site design and reduction of impermeable areas.

Source Control

- Dealing with water where and when it falls (e.g. permeable pavement)

Site Control

- Management of water in the local area (e.g. swales, detention basins).

Regional Control

- Management of runoff from sites (e.g. balancing ponds, wetlands).

See CIRIA C753 *The SuDS Manual Chapters 1 and 2*

Design Principles

The most important requirements are:

- **Ensure that people, property and critical infrastructure are protected from flooding;**
- **Ensure that the development does not increase flood risk off site;**
- **Ensure that SuDS can be economically maintained for the lifetime of the development.**
- **Look to utilise the natural landscape to integrate SuDS**

Runoff Destinations

Surface water runoff not collected for use must be discharged to one or more of the following in the order of priority shown:

- 1) Discharge into the ground (infiltration).
- 2) Discharge to a surface water body.
- 3) Discharge to a surface water sewer, or other surface water system.
- 4) Discharge to combined sewer.

See also The Building Regulations 2010 Part H Drainage and Waste Disposal 2015 Edition

Figure S2: SuDS Management Train

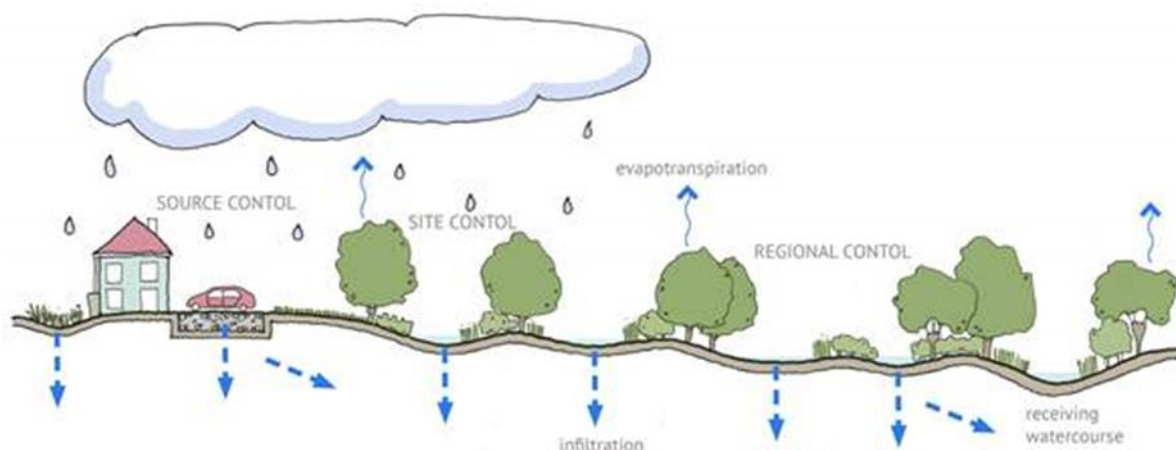

Flood Risk from the Proposed Development

The drainage system must be designed so that, unless an area is designed to hold and/or convey water, flooding does not occur during a 1 in 100 year rainfall event plus an appropriate climate change allowance in any part of a building (including a basement) or in any utility plant susceptible to water (e.g. pumping station or electricity substation) within the development. Calculations must include an allowance for urban creep where required.

The design of the site must ensure that flows resulting from rainfall event in excess of the 1 in 100 year plus climate allowance are managed in exceedance routes that avoid risk to people and property both on and off site.

Peak Flow Control

The peak runoff rate from the developed site for the 1 in 1, 1 in 30 and 1 in 100 year rainfall events to include for urban creep where required and climate change must not exceed the peak greenfield runoff rate from the site for the same event.

Greenfield runoff rate is to be determined using the Institute of Hydrology (IH) Report 124 or Flood Estimation Handbook (FEH) methods. This is detailed in the publication Rainfall Runoff Management for Developments Report SC030219 available at:

<https://www.gov.uk/government/publications/rainfall-runoff-management-for-developments>

See *CIRIA C753 The SuDS Manual Chapter 3*

Volume Control

The runoff volume from the developed site for the 1 in 100 year 6 hour rainfall must not exceed the Greenfield runoff volume for the same event.

Should infiltration methods not be suitable and it is not possible to achieve Greenfield runoff volume then it must be demonstrated

that the increased volume will not increase flood risk on or off site.

See *CIRIA C753 The SuDS Manual Chapter 3*

https://www.ciria.org//Resources/Free_publications/SuDS_manual_C753.aspx

See *Rainfall Runoff management for Developments*

<https://www.gov.uk/government/publications/rainfall-runoff-management-for-developments>

Pollution Control

SuDS design must ensure that the quality of any receiving water body is not adversely affected and preferably enhanced. Any drainage system design should consider use of various SuDS components likely to be appropriate for different contributing and receiving catchment characteristics.

See *CIRIA C753 The SuDS Manual Chapter 4 & 26 for full guidance.*

https://www.ciria.org//Resources/Free_publications/SuDS_manual_C753.aspx

See *Ground Water Protection: See Ground Water Protection Guides at*

<https://www.gov.uk/government/collections/groundwater-protection>

Designing for Exceedance

Site design must be such that when SuDS features fail or are exceeded, exceedance flows do not cause flooding of properties on or off site. This is achieved by designing suitable ground exceedance or flood pathways. Runoff must be completely contained within the drainage system (including areas designed to hold or convey water) for all events up to a 1 in 30 year event.

The design of the site must ensure that flows resulting from rainfall in excess of a 1 in 100 year rainfall event are managed in exceedance routes that avoid risk to people

and property both on and off site. Consider minor interventions to topography, such as dropping or raising kerbs, creating depressions.

See CIRIA C635 *Designing for Exceedance in Urban drainage - Good Practice*

<https://www.ciria.org/ItemDetail?iProductCode=C635&Category=BOOK&WebsiteKey=3f18c87a-d62b-4eca-8ef4-9b09309c1c91>

Highway Drainage

SuDS features within highways and that serve those highways can be adopted by Cumbria County Council Highway Authority and maintained as part of the wider highways maintenance subject to agreement of the Highway Authority. The incorporation of SuDS that involves highway drainage requires the developer either to enter into an agreement under Section 38 of the Highways Act, if involving new development, or an agreement under Section 278 of the Act, if existing highway arrangements are to be modified.

See CIRIA C753 *The SuDS Manual Chapter 9*

Climate Change

Due to changing climate, winters are likely to get wetter and we are likely to experience more extreme weather conditions such as intense rainfall events.

Climate change uplift factors for rainfall intensities, peak river flows and sea level are normally specified by national government and as they are regularly updated are not included in this document. Designers should refer to current guidance from government.

Urban Creep

Urban Creep describes future expansion within a development and activities such as

building extensions and paving gardens. These activities increase the impermeable area of a site and often sit outside of the development control process. As such proposed developments must have an allowance for this increase in impermeable area

Residential development density Dwellings per hectare	Change Allowance % of impermeable area
≤25	10
30	8
35	6
45	4
≥50	2
Flats & Apartments	0

See BS8582:2013 *Code of Practice for Surface Water Management for Development Sites Section 8.*

Construction

Damage caused during the construction phase has the potential to prevent SuDS functioning as required, for example contamination by sediments generated during construction. As such appropriate planning must be applied to surface water management during the construction phase.

Should the SuDS not be proposed to be adopted by a Water and Sewerage Company, upon completion of construction the applicant shall supply full details to Cumbria County Council to allow the authority in its capacity as the Lead Local Flood Authority to fulfil statutory requirements under section 21 of the Flood and Water Management Act 2010 with regard to keeping a register of and information about assets likely to affect flood risk.

See BS8582:2013 *Code of Practice for Surface Water Management for Development Sites Section 10.*

See C698 the Site handbook for the construction of SuDS available from www.susdrain.org/resources/ciria-guidance.html

See CIRIA C753 The SuDS Manual Chapter 31.

Maintenance Requirements

Legislation requires that planning authorities ensure through the use of planning conditions or planning obligations that there are clear arrangements in place for ongoing maintenance of SuDS over the lifetime of the development. Maintenance requirements for proposed SuDS are to be agreed with the Local Planning Authority (LPA). The following options are available:

- 1) Adoption and maintenance of SuDS by the local Water and Sewerage Company via a section 104 Water Industry Act agreement with that company.
- 2) Adoption and maintenance of SuDS by a management company. It must be demonstrated to the satisfaction of the LPA that the maintenance arrangements and their funding will be in place for the lifetime of the development.
- 3) Adoption and maintenance of SuDS relating to highway assessments where agreed with the Local Highway Authority
- 4) Maintenance of SuDS within property curtilages by the homeowner. It must be demonstrated to the satisfaction of the LPA that maintenance will be ensured for the lifetime of the development.

It is not satisfactory to assume that homeowners and subsequent homeowners will be aware of the maintenance requirement and responsibility; further measures will be necessary. Those measures must be proposed by the applicant. Any methods involving designation or registering a Land Charge

are to be agreed with the LPA. The options for maintenance are:

- 1) Maintenance of SuDS within the curtilages of land by the commercial body or organisation that owns or occupies that land. It must be demonstrated to the satisfaction of the LPA that the maintenance arrangements and their funding will be in place for the lifetime of the development.
- 2) Should the SuDS not be adopted by a Water and Sewerage Company the following must be provided:
 - a. As built drawings and a maintenance and operation manual for all SuDS. This must include physical access arrangements for maintenance and establishment of legal rights of access in perpetuity prior to the commencement of any phase of the development. A copy of a maintenance and operation manual for single property SuDS must be supplied to the relevant residents.
 - b. Details of the organisation responsible for the ongoing maintenance of the SuDS for the lifetime of the development.
 - c. Funding arrangements for SuDS maintenance. It must be demonstrated how the ongoing maintenance of the SuDS for the lifetime of the development will be funded.
 - d. Health and safety risk assessment for operation and maintenance of the SuDS

See CIRIA C753 The SuDS Manual Chapter 32.

See BS8582:2013 Code of Practice for Surface Water Management for Development Sites Section 11.

See *Susdrain – SuDS maintenance and adoption options (England)*.

http://www.susdrain.org/files/resources/factsheets/09_15_fact_sheet_suds_maintenance_and_adoption_options_england_.pdf

SuDS Components

Sustainable drainage systems are designed to control surface water run off close to where it falls and mimic natural drainage as closely as possible. They provide opportunities to:

- reduce the causes and impacts of flooding;
- remove pollutants from urban run-off at source;
- combine water management with green space with benefits for amenity, recreation and wildlife.

The full range of SuDS components, including all of the following components, should be investigated to determine which are suitable for the site. Appendix 6 provides a list of SuDS components that the County Council consider appropriate.

Rainwater harvesting
Green Roofs
Permeable Surfacing
Infiltration
Swales
Channels and Rills
Filter Drain
Filter Strips
Bio retention area
Rain gardens
Inlets and Outlets
Detention Basins
Infiltration Basins
Ponds
Wetlands

Appendix 7 provides details of the minimum information that a developer should consider providing when submitting drainage strategy details.

Part 2: Commercial Development

Chapters

- A. Road hierarchy**
- B. Visibility**
- C. Carriageway width**
- D. Junctions and radii**
- E. Turning areas**
- F. Gradients**
- G. Vertical clearance**
- H. Signs & Markings**
- I. Sustainable travel**
- J. Parking**
- K. Utility services**
- L. Lighting**
- M. Landscaping**
- N. Access design**
- O. Mixed use site**

Chapter A. Road hierarchy

New roads in commercial developments should be designed to have a 20mph maximum design speed. The purpose of selecting this speed is that it offers all road users a safer environment for moving around the road network. The design speed should also be recognised as being a maximum and it will be suitable to drop that design speed on lower category roads which are encountered within the development, many of which will be private unadopted carriageway providing direct access to premises.

This guidance does not discern between any particular type of adoptable highway layout within any new commercial development, rather it provides recommendations as to how certain elements should be provided. This includes judgements on whether footways are required on both sides of a carriageway or just one, which will depend more upon how that footway is intended to form a comprehensive and connected network around the site. Decisions such as this should be discussed with the Council's Development Management Officers at concept stage.

Footways

Some suburban or rural located employment sites may be served by a road that does not have footways. Footways should be built into the development and efforts must be made to ensure that although there may be no tie-in possible linkages are made to external footways. This should be done through the provision of dropped kerbs to ends sections of footway as there is little point in providing hardstanding pedestrian routes if some people are prevented from accessing them due to an impairment of some kind.

Footways must be coherent and designed such that they can be seen to serve a defined purpose. Therefore, footways should form a connected network and not suddenly stop unless they are obvious termination points such as accesses into private land or business premises or a cul-de-sac end to the section of carriageway.



Footway section is not connected to anything outside of the site despite the presence of a footway opposite the access



No dropped crossings for pedestrian to use at or near junction



Route for pedestrians is clearly obvious to all road users

(Gillan Way, Penrith)

Cycling

Cycle safety needs to be a major design factor when planning for developments where the regular presence of large vehicles is to be expected. Left turn collisions involving large vehicles and cyclists in recent times shows the necessity for making all road users aware of one another within the space. Separate turning facilities for cyclists at access junctions will lessen this risk but it is equally important that cyclists are guided away from and reintroduced to the carriageway in a safe and obvious manner.

Incorporating cycle lanes across junction mouths can be used as a way of slowing traffic when entering from the major road and also for vehicles on approach the give-way line. Priority still strictly rest with the main carriageway but this feature will create some doubt amongst all road users with the intended effect being that everyone shows more awareness and alertness at this location.



Park Road, Barrow

Additional guidance that relates to visibility splay requirements for cyclists can be found in Part 1 of the Design Guide.

2m is considered wide enough for pedestrian footways but 3m should be used if cycles are to be permitted on a shared use facility.

Shared Surfaces

There will always be questions raised over the practicality of vulnerable road users sharing the same surface as large goods vehicles and buses due their obvious disparity in size. The main issue that is of concern is that of road safety. HGVs are at a disadvantage to most other road vehicles as they can suffer from more limited field of vision, particularly when it comes to seeing hazards that are in very close proximity. With the presence of large heavy goods vehicles it is often better to keep them separated from vulnerable road users such as pedestrians and cyclists.

This separation is recommended on roads which serve multiple accesses to individual business premises. However, once the HGV enters a side road which will include courtyard arrangements or indeed any other car parking layout then the vulnerable road user will become the highest priority in terms of movement through that area.

Footways may still be distinguishable within the highway surface but they should be continuous such that they cut through the space meaning vehicle must cross these footways to enter and leave the area making drivers show caution as they do so.

Measures which are currently in development, both nationally and internationally to mitigate against the risks posed by HGVs to vulnerable road users through the adoption of new technologies that will aid drivers in determining what is around them. Industrial estates will see a great deal of turning manoeuvres by large vehicles within the environment and it is imperative that conflict points are identified and mitigated against within designs.

Chapter B. Visibility

Part 1 of the Design Guide provides explanations and descriptions of both Sight Stopping Distance and Visibility Splays to be at junctions. The data used within Part 1 of the Design Guide is covered by the proviso that the distances which it uses are based upon the assumption that smaller vehicles will make up the majority of travel on those roads. This means that where larger vehicles are expected to account for in excess of 5% of the total traffic flow then an adjustment is required in the data. An adjustment has therefore been applied to this guide due to the highly likely presence and increased frequency of much larger vehicles.

- When Manual for Streets guidance applies, the deceleration rate (d) of a HGV is 3.68m/s^2 which compares to a rate of 4.41m/s^2 for smaller vehicles.
- If speeds are greater than 37mph then DMRB data is used but there is no distinction made between smaller vehicles and HGVs.
- 'X' distance is measured at a junction and is the perpendicular distance from the give-way or stop line

Part 1 of the Design Guide has further guidance on how visibility is determined at junctions, bends and accesses as well as barriers to visibility that should be avoided.

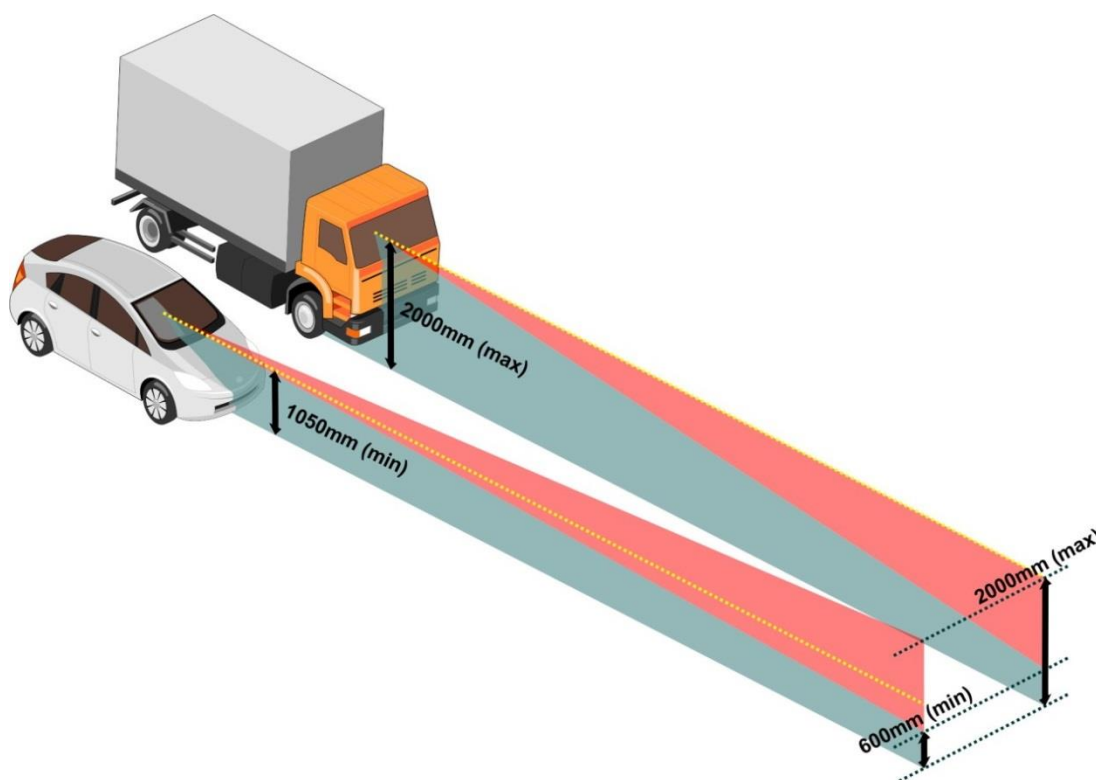

Visibility envelope required

Stopping Site Distances (SSDs) are slightly larger than those required on residential streets.

The Figure below shows the specified distances in relation to a change in highway gradient.

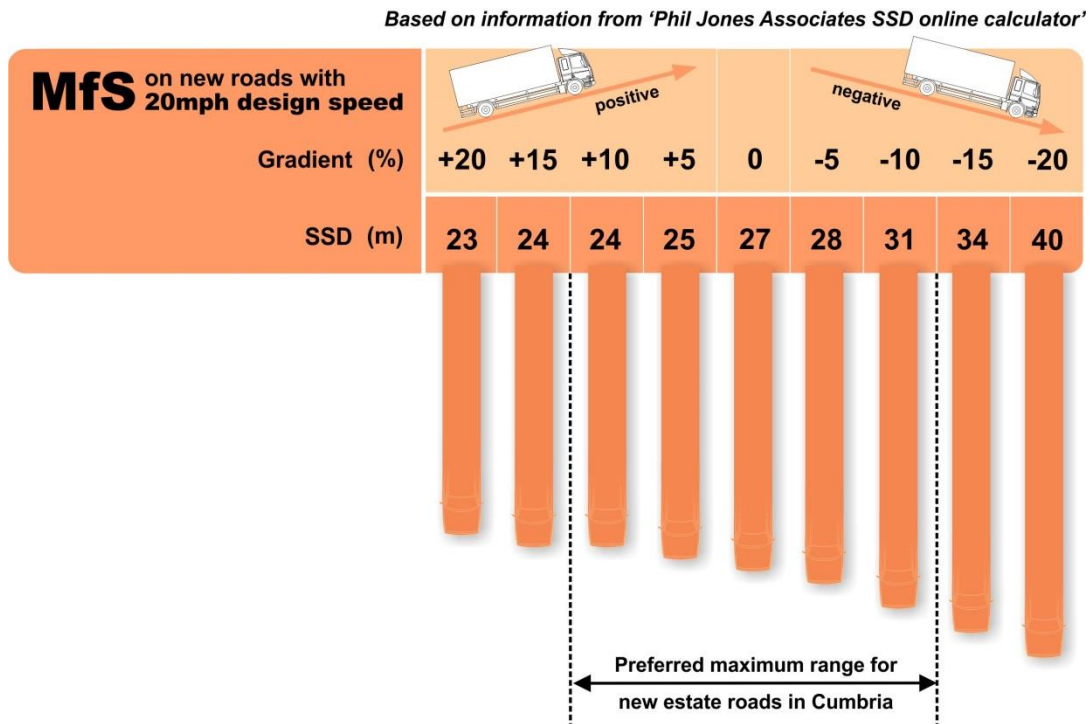

SSDs for different gradients on new roads with 20mph design speed and HGV volumes in excess of 5% of all traffic

Chapter C.

Carriageway widths

The typical width for a carriageway that serves employment sites is 7.3m. This width is considered to be appropriate for allowing two-way traffic flow of HGVs in a safe manner.

W = Typical width of carriageway prior to the bend

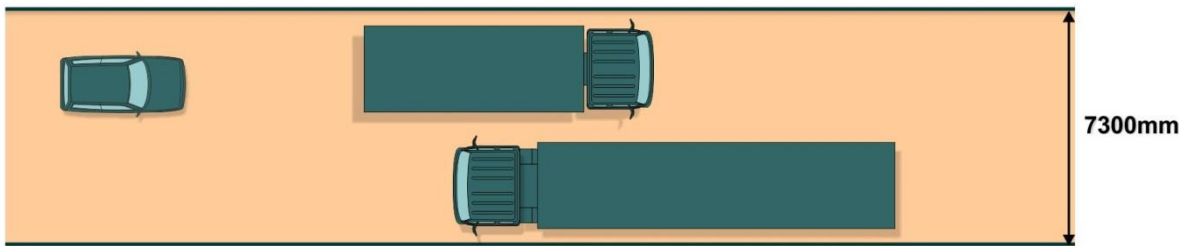

Where a new commercial development is for the purpose of proving office space and no industrial element is required then carriageway widths should be used as put forward in the Part 1 of this guide. Maximum width in such a case will be in the order of 6.75m if the carriageway is designed to accommodate a two-way bus service. The guidance provided within Design Guide should be followed to provide a carriageway width that is best suited to the task it needs to perform. Early engagement with Council's Development Management Officers will assist in this decision.

Additional width requirements

Widening on a bend is very likely on highway which is expected to accommodate a high flow of large vehicles. It is preferable that evidence of swept path analysis can be provided as part of the design process to demonstrate how this has been catered for. As a guide the following table shows typical widening ranges expected as the radius of the bend changes.

Centre-line radius (m)	55 - 74	75 - 89	90 - 150
Width on bend (m)	W + 1.2	W + 0.7	W + 0.6

Over size loads

The different type of business activities that are to be accommodated within the employment site may require special consideration. If a business is likely to generate occasional traffic that is categorised as 'over size' then this is a vital consideration for the highway design. It will mean that central median strips or traffic islands may not be suitable.

The proximity of road lighting, signs, landscaping and other vertical items must all be assessed to ensure they do not present a collision risk if these much wider or longer loads are encountered.

Chapter D. Junctions and Radii

This section is intended to only address junction arrangements which are within new commercial developments. It does not provide direct design technical data on how the new highway connects with the existing highway that serves the site. Designers will need to consider essential data of the existing highway at that point, such as speed (design speed, 85%ile speed, speed limit), gradient of the carriageway on approaches and visibility. Based upon this data it will be possible to identify which guidance (MfS 1& 2 or DMRB) is best suited to the design of a new junction.

A full range of the options available for junction layouts is provided through MfS and is also included within Part 1 of the Design Guide. Not all of those choices will be suitable for use on roads that are expecting to carry a high volume of HGVs. Only those designs which provide the best opportunities for good visibility will be preferred as instances where drivers need to look behind at junctions will create blind spots which are of particular concern for large goods vehicles.

Accesses into commercial developments should be perpendicular to the existing highway network which the new road is to tie into. This arrangement helps to maximise the available visibility for emerging vehicles and minimise blind spots. If there are areas within the new development that large vehicles are to be discouraged from accessing then the more informal arrangement of roads can be incorporated into the design. This would act as a good restriction measure against overuse by large vehicles without the need to put in prohibition signing or markings. Emergency vehicle access must be maintained in any design and these can be found in Part 1 of the Design Guide.

The following junction arrangements have been taken from MfS and their appropriateness to non-residential streets is indicated against each.



Angled side roads will affect visibility for emerging vehicles and swept path of vehicles entering and exiting from all directions.



Visibility is good at cross-roads and will work best when traffic flows are low.



Perpendicular connections of road network means good visibility is achieved.

Junction spacing

25m is the only distance which is stipulated by the Design Guide when it comes to planning of junction proximities. This distance is for junctions that are located on the same side of the carriageway and there is spacing between junctions within a development is therefore not considered to be in need of overly restrictive recommendations when designing for residential developments. It is preferable to assume that this same relaxation can be applied to commercial developments as speeds should be designed to similarly low and as long as sufficient visibility is available at conflict points then this should prove to be a workable approach. If a staggered junction design means that long vehicles are likely to overrun corners when exiting from one road and snaking into the opposite road then designs should be adapted to accommodate this through carriageway construction or design against the movement occurring in the first place.

If sufficiently high enough traffic volumes are anticipated it may become necessary, for the reasons of congestion remediation to introduce minimum spacing and these will be taken from DMRB.

Junction control treatments

Roundabouts

Suitable where high volumes of HGV traffic are anticipated as they can operate with greater efficiency than a priority junction.

There are two types of roundabout which may be used:



Mini-roundabout Circle diameter of the area from kerbline to kerbline will be no greater than 28m



Normal – Inscribed Circle Diameter of no less than 32m with a physically raised centre island of no less than 4m in diameter

Probability of large goods vehicles using roundabouts as U-turn facilities needs to be assessed as mini-roundabouts may be unsuited to that task and physical structures placed in the centre of normal roundabouts may be a collision risk.

Non-signalised junction

This arrangement is dependent upon existing traffic flows across the junction and whether sufficient opportunities exist for traffic to emerge without undue or excessive waiting periods. Typical layouts include T-junctions, cross-roads and staggered junctions that usually rely upon give-way markings and/or signs. These signs and markings can be omitted where traffic speeds are sufficiently low enough and the risk has been assessed through a safety audit.

Signalised junction

This facility is dependent upon existing traffic flows across the junction when judging whether this option is suitable or not. Good design should negate any requirement for signals within a development unless the site is split by a rail track or other segregating feature that cannot be removed as part of the development. Signals at the entrance to the development where it meets with the existing highway network may be necessary.



Signals at the entrance to West Lakes Science Park where it meets the A595

Radii

Large goods vehicles will regularly require access to these roads and it is a must that the design geometry can cope with such movements. Bends are especially susceptible to the movements of these large vehicles if not properly planned for. The cutting of a corner on a bend can lead to infrastructure damage to kerbs, service covers and other vertical structures that may be placed close to the carriageway edge. Over engineering a solution to this issue will lead to other problems as the provision of too generous a sweeping curve means vehicles are able to enter and exit side roads with excess speed and this can cause a significant safety risk. It is crucial that a balance can be struck between creating radii that can cope with the swept path of a large vehicle without leading to safety issues at junctions.

- The radius of a curve on a junction should be a maximum of 10m.
- 6m could be provided if it is done so in combination with an overrun area on the corner.

The design purpose behind using smaller radii means that traffic is forced to perform their turn at a reduced speed than that which would have been possible if the curve was more generous. Pedestrians are also aided by the provision of a smaller radius as they are able keep to their desire line and cross junction with

minimal deflection. Part 1 of the Design Guide includes additional information on this issue.

Structural integrity needs to be applied on corners, particularly those that are designed to **appear** more restrictive in terms of width than they actually are. Giving the impression that a bend is tight forces motorists into making their manoeuvre at slower speeds and with more awareness of what traffic may be coming from the opposite direction.

- This visual device can be achieved through the use of overrun areas which are implemented in a contrasting colour or material. The use of white line hatching should be avoided for the provision of this purpose as they are more likely to need replenishing more frequently and they are visually detracting from the streetscape.
- Overrun areas may be viewed by some as parking places as they are surface finished in a contrasting appearance to the regular blacktop treatment. To prevent this from occurring it may be necessary to implement yellow line restrictions on the bends. Long vehicles may have to enter the opposing lane of travel when turning in at a road junction depending upon how restrictive the corners of the junction are. This will be acceptable where flows are low such as cul-de-sacs that serve a limited number of business premises.
- Visibility splays at junctions should dictate whether such an arrangement can be used or not.

Chapter E. Turning

areas

Permeability is the preferred design ideology behind the creation of new developments. There are many advantages associated with this design option, one of which is the benefit of not having to provide on-highway turning facilities. The reason that this is seen as beneficial is that turning facilities often require vehicles to reverse. This is not an ideal situation when large vehicles are concerned due to the inherent higher collision risk associated with this type of manoeuvre. All turning manoeuvres required by larger vehicles should be encouraged to take place off-highway, ideally within the business premises that the vehicle is attending.

Turning heads can often be seen as an attractive option for parking as they can be seen as being out of the way of the main vehicle carrying alignment of carriageway and plenty long enough to accommodate the full length of a vehicle. This informal parking may very well be acceptable in some cases where traffic flows are low or only small vehicles are expected to use the area. The problem arises when the turning area is the only option available to large vehicles for reverse in and pull out manoeuvres. If these turning areas are occupied then there may be a knock on effect where HGV drivers may attempt to use accesses of businesses within the site to turn their vehicles creating potential conflict points.

Physical turning circles can be used by public transport buses in order to negotiate termination points in their route or on a cul-de-sac which means that they are not forced into making reversing manoeuvres within the highway. Surface treatments within these areas should avoid the over expansive use of blacktop as the sole material due to the detrimental visual impact it has on character.



Turning facility treated with yellow line markings

Speed management

The maximum design speed for any new development road should be 20mph. The geometry requirements of carriageways which are designed for employment sites can unfortunately often carry with it the risk that it will be open to abuse through excessive vehicle speeding and other anti-social vehicle activity. These problems can be magnified for employment sites, perhaps more so than for residential estates because:

- The significant drop in traffic flow and other activity outside of normal working hours means that the roads are very quiet for long periods, particularly overnight.
- The isolated nature of some of these sites means that only minimal levels of observation is carried out by police or general public when compared with residential areas.
- As large vehicles must be accommodated in these developments, the provision of wider carriageways and other general geometry provides a more forgiving layout to those that choose to travel at excessive speed.
- There is less frontage activity expected in employment developments than residential developments and therefore drivers have greater confidence that they are the main priority on that road.

It is not possible or appropriate to apply the same approaches to traffic calming in these estates as for anywhere else on the highway network. The following guidance looks at the different types of speed reduction approaches which could be applied to employment site roads and the reasons behind them.

Where a commercial development serves mainly offices and the proportion of HGVs and other large vehicles is likely to be less then it will be possible to use more traditional traffic calming treatments as described in Part 1 of the Design Guide.

Vertical measures

Vertical traffic calming is not suited to environments with a large capacity of heavy

vehicles. The effect of such devices can have a severe negative effect on vehicles, their loads and their operators and the repeated interaction between HGVs and these devices means that it is more likely that regular maintenance will be required due to the severity of such impacts.

Vertical measures which are encouraged for inclusion are raised tables which can be used at junctions or for major crossing points. The ramps which are used on these tables are more forgiving than a traditional speed hump or cushion device and therefore the transition over them is more comfortable for the driver, passenger and load.

Raised crossing points can be used across access points which allow pedestrians an uninterrupted route in line with any existing footways either side of that access. These raised crossings force drivers into adopting a very low speed due to the increased likelihood of pedestrians asserting their own priority at that location and vehicles choosing to give way to them. The physical height change will also help to persuade drivers that slower is better to preserve their comfort as they cross over the feature.

Horizontal measures

Horizontal traffic calming must be designed to adequately provide for the swept paths of long vehicles without leading to the implementation of a highway feature that does little to affect the speed of smaller vehicles.

The conscious decision of where to place on-street parking within an estate road is seen as an efficient application of traffic calming principles as it doesn't waste opportunities of merging functions such that parking is provided for and speed is curbed in combination. The provision of long unbroken stretches of on-street parking on any one side of the carriageway should be avoided. The recommendation is that discrete lengths be provided, creating a build-out type of arrangement that will narrow the effective carriageway width and encourage caution between oncoming traffic flows.

Psychological measures

Efforts should be made to minimise the amount of road markings used within these estate developments. Excessive use of markings give the impression to motorists that they are the main priority and lane markings tend to give comfort to motorists who are more aware of their allocation of road space and consequently they are more inclined to travel at speed.

- With such limited options that could be employed in these areas, particular emphasis should be placed on the alignment of the carriageway.
- Ensuring that the use of long unbroken straights is avoided will create some speed reducing effect
- Avoiding the provision of excessive visibility splays at junctions and accesses within the sites should make motorists use greater caution when entering/exiting and pedestrians will be equally encouraged to demonstrate caution at crossing points.

Chapter F. Gradients

Guidance on what is expected of developers when dealing with gradients on the highway is provided in Part 1 of the Design Guide.

Severity of carriageway gradients will have a more significant impact on large vehicles stopping ability when compared to lighter vehicles and this is recognised through differences in SSD which is covered in the Visibility section of this guide.

A maximum value of 10% should be assumed for new highway with Cumbria County Council's adoptable highway.

Chapter G. Vertical clearance

The same guidance applies to commercial developments as that which is contained within the Part 1 of the Design Guide when it comes to adequate clearance for footways, shared footways and segregated cycleways. New commercial developments should not introduce any overhead feature that enters into the carriageway space at a height of less than 5.3m. If it is known that the type of business activity within the development will require clearance height of greater than 5.3m this will affect decisions over the placement and maintenance of trees and lighting in the highway.

Chapter H. Signs & markings

Development Boundary Signage

Although this sign is not an official highway sign it can nevertheless have a significant effect on road safety and driver behaviour at access points. Gateway treatments can lend a development an identity which assists in the process of the site becoming established in a community or other surroundings.

The selection of a design for a development's threshold sign will be influenced by a number of factors including the size of the site, available space into which a sign could be located

It is recommended that the signage is positioned such that it is clearly visible from the highway network in order that approaching vehicles have sufficient time to observe the access and make their manoeuvre safely. The benefit of this would be that additional highway signs may not be needed to emphasise the junction and this will minimise sign clutter.



Large scale development uses bespoke sign positioned so it is easily viewed from the existing highway network



Signing is 'too' discrete leading to situations where visitors pass by the entrance and have to turn around

Development layout signage

Map type signs are often used within industrial estates, business parks and the like to show the approximate location of businesses on the inner road network. These types of signs are arguably becoming less of a necessity due to the widespread use of satellite navigation aids which can direct drivers directly to the building without the reliance on road signs.

Where these map type signs are to be provided, they should be located so that they do not create movement issues for traffic. If these signs are placed too close to the junction and there is not sufficient space for the visitor to pull over and read the sign then a hazard could result with the carriageway width being effectively narrowed at that point.

It is therefore important that sufficient distance is ensured such that motorists pausing to read the sign do not cause a hazard for following vehicles entering from the junction. The design could incorporate an off-carriageway bay that may be used by visitors to pause and allow sufficient time to view the detail of the sign.

Unofficial advertising

Unofficial signing can creep into the highway and care must be taken to make sure that these advertisements do not create issue such as blocking footways, visibility splays and that they don't shield essential highway signs. The County Council have a policy in place which means unofficial signs can be removed but it would be preferable if thought could be given from the outset as to how commercial signage will work best without the need for additional A-boards and such like appearing.



Shap Rd, Kendal



Example of map sign

Markings

If a maximum design speed of 20mph can be achieved, then there should be no safety critical reason for using centre lining. Road users should be moving at slow enough speeds so they are fully able to judge their position within the carriageway in relation to other oncoming vehicles and ensure everyone has the width that they need.

Yellow lining will be acceptable if a Traffic Regulation Order requires enforcing but consideration should be given to alternative ways of providing the same functions, perhaps through the use of restricted parking zones that require fewer road markings.

The benefits of reducing the number of markings within the highway is that it visually improves the roadscape through decluttering and also means that future maintenance is reduced as lines do not require renewing.

Bollards

Bollards will generally give off the impression of being a retro-fitted item which demonstrates to road users that the highway design has failed to work in some way. It is imperative that developers seek to design out this negative impression when a new highway is being proposed.

Bollards will not be accepted as an appropriate means of providing traffic management for any new industrial development unless it can be reasonably proved that no other less intrusive preventative method could be used as an alternative. If there is an issue with a design that suggests it is highly probable that vehicles will cut a corner at a bend in the carriageway, potentially putting pedestrians or property at risk then this should be addressed through the design itself, not through the installation of bollards.

The use of vertical infrastructure such as bollards in close proximity to the carriageway can become a significant maintenance issue if they are frequently struck. This not only means additional costs are incurred in replacing the items but if left in place following a collision they may pose a threat to other road users such becoming a trip hazard.

An exception to the aforementioned aversion to implementing bollards may be on shared footways which due to their width may be potentially open to abuse from road traffic. The appropriate placement of a bollard centrally within that footway will help to avoid confusion or abuse by motor vehicles by physically preventing them access.



Concrete bollard with shared facility signage

Guardrailing

New commercial developments should avoid the use of guardrailing unless there is compelling evidence which shows this is the most appropriate solution. The need for their provision should be designed out of the scheme by means of appropriate layouts and highway geometry. Places where guardrailing may traditionally have been encountered before would have included; formal crossings, on the corners of junctions and severe bends and where footways meet the carriageway at a perpendicular angle, often from a hidden or shielded route.

Chapter I. Sustainable Travel

Travel plans

Cumbria County Council, as Highway and Transport Authority, is keen to see Travel Plans used effectively and will be working towards this goal in partnership with Cumbria's Local Planning Authorities. Cumbria County Council has the following guidance to assist developers and their consultants to understand when a travel plan will be required and the expected content of the travel plan.

Travel Plans and the Planning Process in Cumbria: Guidance for Developers

Travel plans form a fundamental part of the development management process. It is therefore a requirement that where development proposals meet threshold levels, or where a travel plan is specifically requested, a travel plan is produced to accompany the developer's planning application. The most applicable categories have been drawn out and included here for quick viewing but the more comprehensive list included the aforementioned guidance should always be checked regardless.

Public Transport

Depending upon the scale of development being provided it may be necessary to incorporate bus stopping facilities within the newly created highway. If it is desirable to provide this service then designs should seek to ensure infrastructure which has been identified for that purpose is not adversely affected by other road users.

Bus laybys for instance are often open to abuse from unauthorised vehicles using them as parking bays. If not properly enforced this situation can continue and soon becomes the norm rendering the initial design concept as a failure. Laybys should only be provided if there is a requirement for a Bus Stay as opposed to a Bus Stop. A simple set down and pick up arrangement from the kerblines of the

The main benefits of travel plans which are applicable to the workplace include:

Reduction in parking costs
Saving costs on business travel
Tax relief
Improved access to work
Reduced congestion on commute
Improved travel choices
Improved company image
Healthier workforce

Travel plan measures will generally address the following issues which will be key to commercial developments:

- Walking
- Cycling
- Public transport
- Car Sharing
- Working Practices
- Car Parking Management
- Promotion

carriageway running lane should be sufficient for this purpose and if flows are sufficiently low enough then traffic will not be too adversely affected.

Previously within this guide reference has been made to the recommendation that buses should not have to perform reversing manoeuvres in order to navigate the development.

Chapter J. Parking

Businesses operating on the site should be providing an adequate quantity of spaces for their own staff, visitors, trade, deliveries and storage of vehicles on-site.

Verges without footways need to prevent inappropriate parking which can destroy the verge material, create drainage issues, be an obstruction to other traffic and pedestrians.

Indiscriminate parking can block the entire width of footways as the 2m width is seemingly ideal for cars and light goods vehicles. This pushes vulnerable road users out into the live carriageway creating a road safety risk. Damage can also be done to the footway if the sub-base construction or surface materials are not intended for vehicles. Kerb upstands will suffer from vehicles mounting and dismounting them with dropped kerbs to be used at official footway crossing points.

Long stay and short stay arrangements need to be considered and how such facilities can be monitored so that they can be used according to their intended function.

Areas where trailer transfers can take place should be built into the design to prevent issues arising with these large unattended units causing an obstruction around the site.



Footway parking, Shap Road Industrial Estate, Kendal



Footway is rendered practically inaccessible through encroachment of parked vehicles



Burgh Road Industrial Estate, Carlisle

Guidance on parking numbers can be found in Appendix 1



Yellow lining added retrospectively to prevent obstructive footway parking

Permitted on-street parking

Where carriageway width and traffic flows will permit it, developers should consider the visual demarcation of parking bays on the highway. The use of white markings in providing this facility is not recommended rather it is preferable if the parking bay areas can be identified in some contrasting material or colour. If road users are visually informed where it is appropriate to park they will be less inclined to make their own decisions and risk parking half-on half-off footways, verges and on both sides of a carriageway.

If bollards are being suggested to prevent footway parking because the footway is not sufficiently constructed to a standard which can withstand the weight of HGVs then this will be deemed unacceptable. Inappropriate parking will impact on footway condition so must be constructed to allow for this if it is a likely possibility.

Layout of privately owned car parks

The layout arrangement of parking bays within the boundary of a private business is outside of the influence of the Highway Authority. However, although it is advisable to keep loading and service bays out of that car park space where ever possible. The provision of separate facilities for non-parking activities removes manoeuvres that would otherwise pose a collision risk with vulnerable road users and parked or parking vehicles.

If buildings are planned so that they are positioned closer to the highway network than their car parks they are easier to access by foot. This is encouraged as an arrangement because vulnerable road users are not placed at 'unnecessary' risk by making them pass through an area where vehicles are reversing and turning. It is mainly larger car parks with multiple rows of bays which are seen to create this barrier.



Traffic is split to avoid conflict, Shap Road Industrial Estate, Kendal

Cycle parking

Cycle parking should be provided by businesses on their own premises and according to current parking guidelines. Cycle parking within the highway limits is not anticipated to be a common occurrence unless there are appropriate activity generators that would create a demand. Examples may include communal recreation areas or picnic facilities that are intended for use by all businesses on the site.

Where cycle parking is provided within the highway it should be fit for purpose and maintainable if it is to be adopted by the Highway Authority. Any bespoke features that may be introduced and which may incorporate cycle parking will require a robust future maintenance plan.

Chapter K. Utility services

The advice from Design Guide should also be applied to commercial developments with a particular emphasis on early engagement

between developer and utility companies recommended. There should be no services placed within the constraints of the carriageway and should instead be kept within the margins of available footways or allocated maintenance strips.

Chapter L. Lighting

Cumbria County Council's Road Lighting Policy 2014 sets out the following objectives for the provision and maintenance of road lighting:

- to provide a safe network for all highway users, taking into account the needs of more vulnerable groups, but with the principal aim of reducing night-time accidents.
- to maintain lighting to a standard which ensures as far as possible a safe, economic, effective and reliable use of the highway during the hours of darkness.
- to contribute to crime reduction strategies by improving lighting where funding is available in order to provide a safer night-time environment.
- to contribute to the economic well-being of the County by helping transport movements and enhancing the night-time environment of urban areas, including tourist centres.
- to protect the night-time environment by setting levels of lighting provision which reflect the variety and diversity of the County

The policy also includes a guide to the kind of lighting requirements which would be expected for application in different character areas found within Cumbria. These areas range from rural settlements within National Parks to larger urban areas.

The need to provide road lighting throughout the hours of darkness will depend upon the requirements of the businesses within the commercial development. Those that require access around the clock may benefit from a lit carriageway, particularly if employees working shifts are arriving and leaving by foot or cycle.

The presence of trees can have an impact on the effectiveness of lighting in terms of the blockage of light or structural damage that may occur to the unit. The placement of new lighting columns in the vicinity of existing trees or the introduction of new trees as part of a

landscaping plan must be assessed thoroughly and the lighting design should therefore be carried out in consultation with landscape architects or suitable qualified professionals.

Keeping lighting columns at the back of footways not only helps with keeping through routes clear for pedestrians and cyclists where shared facilities are used, but also lessens the opportunities for vehicles to collide with them which can be a real concern with the presence of long or oversize vehicles with significant overhangs.

Further detailed guidance can be found in Appendix 10.

Chapter M.

Landscaping

It is important to assess the purpose which landscaping is fulfilling within commercial developments. The use of planting can create an aesthetically pleasing environment, softening the visual impact of industrial units on the environment. It is essential however that this treatment does not compromise the efficiency of the highway and all soft landscaping works must be maintainable without the need for disproportional attention.

Shielding heavy industrial practices from the general public is preferred as it is both unsightly and distracting for drivers. This does not mean that all parts of a site should be hidden away however due to the need to maintain natural surveillance of the area.

Don't implement thick foliage planting where it will shield side roads and pedestrian accesses from the carriageway. Although restricting visibility can be useful for encouraging caution in road users they must also be made aware of the presence of the junctions.

Verges within commercial developments can often be open to abuse by parking. Appropriate materials should be used to prevent parking on soft verges or if it is to be expected then the surface should be designed to withstand this. Preventative planting such as low level, thick foliage could be used as a deterrent. This method also acts as a natural alternative to a row of bollards as vehicles will be less inclined to enter the space. Visibility at junctions must be maintained and a maximum height of 0.6m for vertical obstructions should apply.

Products such as 'Grasscrete' may be used to provide the illusion of landscaping but also allow for parking to take place without any undue and unsightly effect on the greenery.



Chapter N. Access design

From the existing highway network

When a new development is created, decisions about its visual impact will have been made as part of the design and subsequent planning process. The intention for the development may be to make a bold statement which makes it stand out in some way, perhaps in an effort to provide some rejuvenation of the location into which it is going? Another possibility is that the new development should blend in with the current surroundings so that the quality of that surrounding area can be assured. These different approaches will undoubtedly require different treatments in order to inform people of the development's presence and essentially where and how it can be accessed.



If pedestrian facilities are in place on the existing highway network and pass by the new access point, segregated access should be provided. It is not recommended that all road users are required to use the same surface when accessing or exiting a development.

Entrances to industrial estates should avoid the use of central pedestrian refuges or islands as they are a collision risk which is unlikely to remain free from impacts

The highway must not be infringed upon by arrangements at private accesses. This means that there must be no blockage

created by vehicles that are accessing or egressing the private premises that will impact negatively on the public highway. Access arrangements may mean that it will be impractical for a vehicle to enter the access unless they give way to exiting vehicles and this will be acceptable so long as the waiting vehicle is not made to wait for excessive periods of time.

A swept path analysis undertaken by the designer should highlight any issues with long articulated vehicles moving in or out of side roads or private premises. Excessive sweeps that takes that vehicle into oncoming traffic lanes may not be acceptable if traffic flows are such that this will become a regular hazard.

Any gated access to private lane should be designed so that the gates open away from the carriageway and into the site. Gates should not create barriers to any part of the highway at any time, including footways. Gates that slide open parallel to the carriageway are preferred if they can be accommodated within the site.



Perimeter gate which opens in parallel to the carriageway and within the site boundary.

Chapter O. Mixed Use sites

Commercial developments are able to accommodate a great range of business activity within them from small workshop based enterprises to large scale industrial complexes. If discrete areas are intended for the sole purpose of the smaller scale business units such as those which are based around a courtyard parking arrangement, then these areas may benefit from their access point being treated differently to the rest of the highway.

Some form of raised entry could perhaps provide the necessary visual clue that HGVs should not be entering that space. This raised access would also prove beneficial to pedestrians and cyclists who would be able to use the feature as a crossing without the need for dropped kerbs.

Various other methods could be used to provide this visual deterrent to larger vehicles using the development but the use of signs that give a warning or prohibition message should not be the preferred solution. Physical design options should be used first and foremost to allow a self-enforcement of the access arrangement and a TRO should only be considered as a last resort or if a problem persists. The creation of restricted zones can mean a reduction in yellow lining as vehicles can only use marked bays within a zone and those bays can and preferably should be marked out by a method other than painted white markings.

If visibility is good between the side road area and the other road then it may be possible to use a single vehicle width entry/exit where vehicles would be forced into giving way to one another to allow for access and egress. This arrangement would act as a deterrent to large vehicles attempting to enter the space and would create traffic calming for other vehicles at the access. The use of such a design would be subject to anticipated traffic volumes using the access and any knock-on

effect that queuing traffic would have on the main road.

It is important to note that if loading must take place within this courtyard area then HGVs may still enter but only those that have a direct reason for visiting the site